



QT Electric Actuator



◆ Features

- Exquisite design, excellent performance, light weight and big output torque.
- The inside and outside of closure is treated by hard oxygen, while epoxy resin + powder spraying are adopted for external treatment, which posses good antiseptic performance.
- Protective grade of product is upward of IP67.
- Connection dimension of output end is in accordance with the National Standard ISO5211.
- Connection shaft sleeve can be replaced, and easily processed and installed.
- Double worm wheels structure, which has self-locking function, and is of external adjustable mechanical limit.
- Power-driven/manual operation mode can be changed easily through hand shank, then automatic reset to electronic control after power on.
- Built-in torque switch, and carry out overload protection on electric actuator. Moreover, it embedded thermal protector to carry out dual-protection on electrical machine.
- Indicate the valve position continuously by big window for better viewing.
- Multiple filed control unit, provide the best performance according to the requirement of users.
- Intelligent control unit could be selected.



Indicator



ISO5211 Actuator Mounting



Terminal Block



Worm Gearing

◆ Technical Data and Specifications

Model	Max output torque NM	90° operating time 60/50Hz S	Max bore size mm	F-class motor W	Rated current(A) 60/50HZ				Handwheel rotation N	Weight Kg
					Single-phase		Three-phase			
					10V	220V	380V	440V		
QT-010	100	18/22	Φ20	20	1.10/0.95	0.55/0.54	0.3/0.3	N/A	10	7.5
QT-020	200	21/25	Φ22	40	1.67/1.67	0.89/0.85	0.31/0.31	0.30/0.31	11	17.3
QT-030	300	26/31	Φ35	60	1.85/1.86	0.92/0.92	0.35/0.35	0.34/0.34	13.5	22
QT-050	500	26/31	Φ35	90	3.60/3.62	1.55/1.58	0.59/0.59	0.58/0.58	13.5	23
QT-080	800	31/37	Φ45	120	4.10/4.10	2.15/2.20	0.85/0.85	0.79/0.79	16.5	29
QT-100	1000	31/37	Φ45	180	4.20/4.10	2.35/2.30	0.87/0.87	0.81/0.81	16.5	29
QT-160	1600	93/112	Φ60	180	4.10/4.10	2.15/2.20	0.85/0.85	0.79/0.79	49.5	75
QT-200	2000	93/112	Φ65	180	4.10/4.10	2.15/2.20	0.85/0.85	0.79/0.79	49.5	75



Modulating Type



On-off Type



QT ELECTRIC ACTUATOR

◆ Standard Specification

Shell	Waterproof level IP67,NEMA4 and 6	
Motor power	Standard: 220V AC Single-phase Optional: 110V AC Single-phase, 380/440V AC Three-phase, 50/60Hz, ± 10% 24V DC / 110V DC / 220V DC	
Motor	Squirrel-cage asynchronous motor	
Limit switch	Open/close, each 1 SPDT, 250VAC10A	
Auxiliary limit switch	Open/close, each 1 SPDT, 250VAC10A	
Torque switch	Open/close, each 1 SPDT, 250VAC10A	Except QT-005/008-010
Stroke	90° ± 10°	0° ~27° Optional
on / operating temperature	Inside overheating protection, open 115°C ± 5°C/close 97°C ± 5°C	
Indicator	Continuous position indicator	
Manual operate	Declutching mechanism, cooperate with handwheel	
Self-locking device	Provide self-locking by worm and worm gear	
Mechanical limit	2piece of external adjustable bolt	
Space heater	7-10W(110/220V AC)	
Conduit entry	2个(pieces)PE3/4"	
Ambient temperature	-20°C~+70°C	
Lubrication	Aluminum base grease(EP type)	
Material	Steel, aluminum alloy, aluminum bronze, polycarbonate	
Ambient humidity	Max 90% RH	Non condensation
Anti-vibration performance	XYZ10g, 0.2~34Hz, 30 Minutes	
External coating	Dry powder, epoxy polyester, strong anti-corrosion function	

◆ Optional Specifications

No	Optional configuration	Remarks
1	Explosion-proof actuator(Exd II BT4, Exd II CT6)	QT Series
2	Waterproof actuator(IP68, 10M, 250HR)	QT Series
3	Potentiometer(1K-10K)	QT Series
4	Proportional control unit(Input, output signal)4-20mA DC/1-5V/1-10V)	QT Series
5	Field control unit(local control open/stop/close switch, local/remote control switch)	QT Series
6	Stroke 120° , 180° , 270°	QT Series
7	DC motor(24V DC)	QT Series
8	Additional torque switch(SPDT X 2 250V AC 10A)	Except QT-005/008/010
9	Current position sensor(Output 4-20mA DC)	QT Series
10	After cutting power, the electric valve automatically open or close the control cabinet	QT Series
11	High temperature resistant actuator(-10°C~+100°C)	QT Series
12	Low temperature resistant actuator(-40°C~+70°C)	QT Series
1	Low speed actuator	QT Series

◆ GENERAL DRAWING

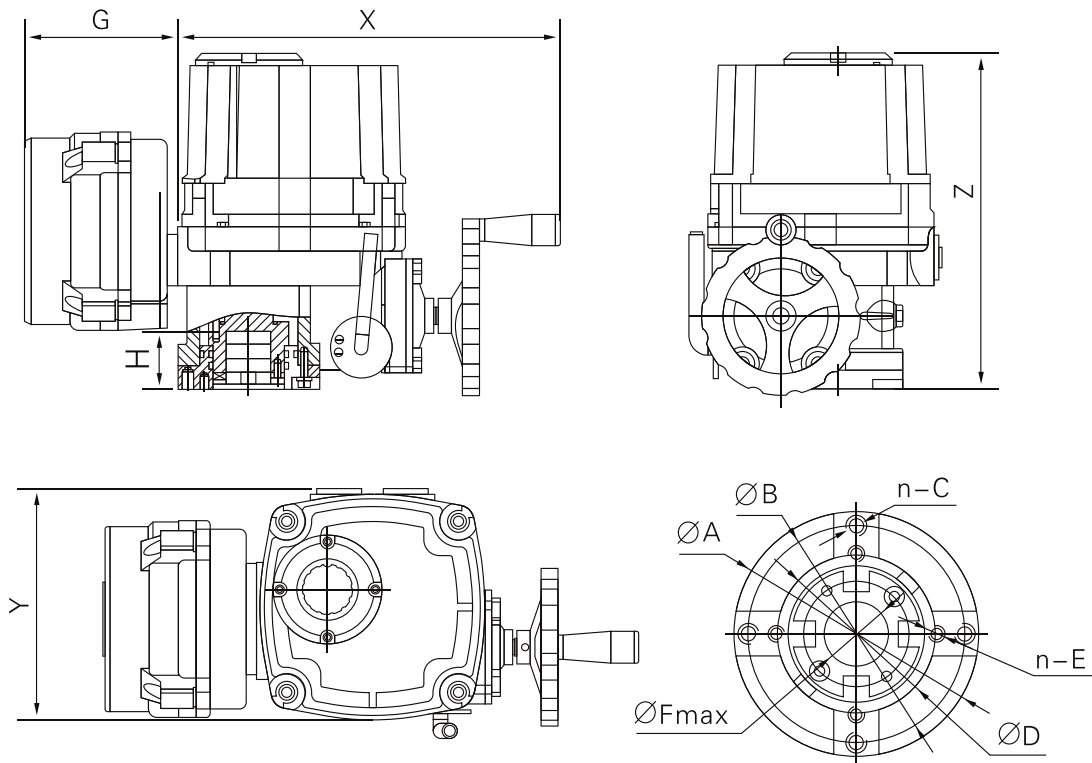

Model	X	Y	Z	A	B	N-C	D	N-E	F	G	H
QT-010	270	161	234	Φ90	Φ70	4-M8	Φ50	4-M6	Φ20	137	35
QT-020	346	240	270	Φ120	Φ102	4-M10	Φ70	4-M8	Φ22	137	40
QT-030	358	240	290	Φ150	Φ125	4-M12	Φ102	4-M10	Φ35	137	45
QT-050	358	240	290	Φ150	Φ125	4-M12	Φ102	4-M10	Φ35	137	45
QT-080	390	260	322	Φ180	Φ140	4-M14	Φ125	4-M12	Φ45	137	55
QT-100	390	260	322	Φ180	Φ140	4-M14	Φ125	4-M12	Φ45	137	55
QT-160	390	260	491	Φ210	Φ165	4-M16	Φ140	4-M14	Φ55	137	65
QT-200	390	260	491	Φ210	Φ165	4-M16	Φ140	4-M14	Φ55	137	65



AVK Sverige AB/INDVA
 Industrigatan 28
 28143 Hässleholm

info@indva.se
 0046 451 74 69 00
 www.indva.se - www.avkvalves.se