



## Multi-turn actuators

SA 07.2 – SA 16.2

SAR 07.2 – SAR 16.2

Control unit: electronic (MWG)

with actuator controls

AC 01.2 Non-Intrusive

### Control

Parallel

→ Profibus DP

Profinet

Modbus RTU

Modbus TCP/IP

Foundation Fieldbus

HART



**Read operation instructions first.**

- Observe safety instructions.
- These operation instructions are part of the product.
- Store operation instructions during product life.
- Pass on instructions to any subsequent user or owner of the product.

**Target group:**

This document contains information for assembly, commissioning and maintenance staff.

**Reference documents:**

- Manual (Operation and setting) of actuator controls AC 01.2 Profibus DP
- Manual (Fieldbus device integration) of actuator controls AC 01.2 Profibus DP

Reference documents are available on the Internet at: <http://www.auma.com>.

**Table of contents**

**Page**

<b>1.</b>	<b>Safety instructions.....</b>	<b>5</b>
1.1.	Prerequisites for the safe handling of the product	5
1.2.	Range of application	5
1.3.	Warnings and notes	6
1.4.	References and symbols	6
<b>2.</b>	<b>Short description.....</b>	<b>7</b>
<b>3.</b>	<b>Name plate.....</b>	<b>9</b>
<b>4.</b>	<b>Transport and storage.....</b>	<b>13</b>
4.1.	Transport	13
4.2.	Storage	15
<b>5.</b>	<b>Assembly.....</b>	<b>17</b>
5.1.	Mounting position	17
5.2.	Handwheel fitting	17
5.3.	Mount actuator to valve	17
5.3.1.	Overview of output drive types	18
5.3.2.	Output drive type A	18
5.3.2.1.	Multi-turn actuator with output drive type A: mount	19
5.3.2.2.	Stem nut for output drive type A: finish machining	21
5.3.3.	Output drive types B/C/D and E	22
5.3.3.1.	Multi-turn actuator with output drive type B: mount	23
5.4.	Accessories for assembly	24
5.4.1.	Stem protection tube for rising valve stem	24
5.5.	Mounting positions of local controls	25
5.5.1.	Mounting positions: modify	25
<b>6.</b>	<b>Electrical connection.....</b>	<b>26</b>
6.1.	Basic information	26
6.2.	SD electrical connection (AUMA plug/socket connector)	29
6.2.1.	Terminal compartment (for mains connection): open	30
6.2.2.	Cable connection	31
6.2.3.	Terminal compartment (for mains connection): close	32
6.2.4.	Fieldbus terminal compartment: open	33

6.2.5.	Fieldbus cables: connect	34
6.2.6.	Fieldbus terminal compartment: close	35
6.3.	Accessories for electrical connection	36
6.3.1.	Actuator controls on wall bracket	36
6.3.2.	Parking frame	37
6.3.3.	DS intermediate frame for double sealing	37
6.3.4.	External earth connection	38
<b>7.</b>	<b>Operation.....</b>	<b>39</b>
7.1.	Manual operation	39
7.1.1.	Manual valve operation	39
7.2.	Motor operation	40
7.2.1.	Operating the actuator from local controls	40
7.2.2.	Actuator operation from remote	41
7.3.	Menu navigation via push buttons (for settings and indications)	41
7.3.1.	Menu layout and navigation	42
7.4.	User level, password	43
7.4.1.	Password entry	44
7.4.2.	Password change	44
7.4.3.	Timeout for incorrect password entry	45
7.5.	Language in the display	45
7.5.1.	Language change	45
<b>8.</b>	<b>Indications.....</b>	<b>47</b>
8.1.	Indications during commissioning	47
8.2.	Indications in the display	47
8.2.1.	Feedback signals from actuator and valve	48
8.2.2.	Status indications according to AUMA classification	50
8.2.3.	Status indications according to NAMUR recommendation	51
8.3.	Indication lights of local controls	53
8.4.	Optional indications	54
8.4.1.	Mechanical position indication (self-adjusting)	54
8.4.2.	Mechanical position indication via indicator mark (not self-adjusting)	54
<b>9.</b>	<b>Signals (output signals).....</b>	<b>55</b>
9.1.	Signals via fieldbus	55
9.2.	Status signals via output contacts (digital outputs)	55
9.2.1.	Assignment of outputs	55
9.2.2.	Coding the outputs	55
9.3.	Analogue signals (analogue outputs)	56
<b>10.</b>	<b>Commissioning (basic settings).....</b>	<b>57</b>
10.1.	Type of seating: set	57
10.2.	Torque switching: set	58
10.3.	Limit switching: set	60
10.4.	Fieldbus address (slave address): set	62
10.5.	Test run	62
10.5.1.	Direction of rotation at mechanical position indicator: check	63
10.5.2.	Direction of rotation at hollow shaft/stem: check	64
10.5.3.	Limit switching: check	64
<b>11.</b>	<b>Commissioning (settings/options in the actuator).....</b>	<b>66</b>
11.1.	Switch compartment: open/close	66

11.2.	Mechanical position indicator (self-adjusting)	67
11.2.1.	Mechanical position indicator: set	67
11.2.2.	Gear stage of the reduction gearing: test/set	68
11.3.	Mechanical position indication via indicator mark (not self-adjusting)	69
11.3.1.	Mechanical position indicator: set	69
11.3.2.	Gear stage of the reduction gearing: test/set	69
<b>12.</b>	<b>Corrective action.....</b>	<b>72</b>
12.1.	Faults during commissioning	72
12.2.	Fault indications and warning indications	72
12.3.	Fuses	76
12.3.1.	Fuses within the actuator controls	76
12.3.2.	Fuse replacement	77
12.3.2.1.	Replace fuses F1/F2	77
12.3.2.2.	Test/replace fuses F3/F4	78
12.3.3.	Motor protection (thermal monitoring)	78
<b>13.</b>	<b>Servicing and maintenance.....</b>	<b>80</b>
13.1.	Preventive measures for servicing and safe operation	80
13.2.	Maintenance	81
13.3.	Disposal and recycling	81
<b>14.</b>	<b>Technical data.....</b>	<b>82</b>
14.1.	Technical data Multi-turn actuators	82
14.2.	Technical data Actuator controls	84
14.3.	Tightening torques for screws	90
<b>15.</b>	<b>Spare parts.....</b>	<b>91</b>
15.1.	Multi-turn actuators SA 07.2 – SA 16.2/SAR 07.2 – SAR 16.2	91
15.2.	AC 01.2 actuator controls with SD electrical connection	93
	<b>Index.....</b>	<b>97</b>

## 1. Safety instructions

### 1.1. Prerequisites for the safe handling of the product

<b>Standards/directives</b>	<p>The end user or the contractor must ensure that all legal requirements, directives, guidelines, national regulations and recommendations with respect to assembly, electrical connection, commissioning and operation are met at the place of installation.</p> <p>They include among others:</p> <ul style="list-style-type: none"><li>• Applicable configuration guidelines for fieldbus applications.</li></ul>
<b>Safety instructions/warnings</b>	<p>All personnel working with this device must be familiar with the safety and warning instructions in this manual and observe the instructions given. Safety instructions and warning signs on the device must be observed to avoid personal injury or property damage.</p>
<b>Qualification of staff</b>	<p>Assembly, electrical connection, commissioning, operation, and maintenance must be carried out by suitably qualified personnel authorised by the end user or contractor of the plant only.</p> <p>Prior to working on this product, the staff must have thoroughly read and understood these instructions and, furthermore, know and observe officially recognised rules regarding occupational health and safety.</p>
<b>Commissioning</b>	<p>Prior to commissioning, imperatively check that all settings meet the requirements of the application. Incorrect settings might present a danger to the application, e.g. cause damage to the valve or the installation. The manufacturer will not be held liable for any consequential damage. Such risk lies entirely with the user.</p>
<b>Operation</b>	<p>Prerequisites for safe and smooth operation:</p> <ul style="list-style-type: none"><li>• Correct transport, proper storage, mounting and installation, as well as careful commissioning.</li><li>• Only operate the device if it is in perfect condition while observing these instructions.</li><li>• Immediately report any faults and damage and allow for corrective measures.</li><li>• Observe recognised rules for occupational health and safety.</li><li>• Observe national regulations.</li><li>• During operation, the housing warms up and surface temperatures &gt; 60 °C may occur. To prevent possible burns, we recommend checking the surface temperature prior to working on the device using an appropriate thermometer and wearing protective gloves.</li></ul>
<b>Protective measures</b>	<p>The end user or the contractor are responsible for implementing required protective measures on site, such as enclosures, barriers, or personal protective equipment for the staff.</p>
<b>Maintenance</b>	<p>To ensure safe device operation, the maintenance instructions included in this manual must be observed.</p> <p>Any device modification requires prior written consent of the manufacturer.</p>

### 1.2. Range of application

AUMA multi-turn actuators SA 07.2 – SA 16.2/SAR 07.2 – SAR 16.2 are designed for the operation of industrial valves, e.g. globe valves, gate valves, butterfly valves, and ball valves.

Other applications require explicit (written) confirmation by the manufacturer.

The following applications are not permitted, e.g.:

- Industrial trucks according to EN ISO 3691
- Lifting appliances according to EN 14502
- Passenger lifts according to DIN 15306 and 15309

- Service lifts according to EN 81-1/A1
- Escalators
- Continuous duty
- Buried service
- Continuous underwater use (observe enclosure protection)
- Potentially explosive areas
- Radiation exposed areas in nuclear power plants

No liability can be assumed for inappropriate or unintended use.

Observance of these operation instructions is considered as part of the device's designated use.

**Information** These operation instructions are only valid for the "clockwise closing" standard version, i.e. driven shaft turns clockwise to close the valve.

### 1.3. Warnings and notes

The following warnings draw special attention to safety-relevant procedures in these operation instructions, each marked by the appropriate signal word (DANGER, WARNING, CAUTION, NOTICE).



**Indicates an imminently hazardous situation with a high level of risk. Failure to observe this warning results in death or serious injury.**



**Indicates a potentially hazardous situation with a medium level of risk. Failure to observe this warning could result in death or serious injury.**



**Indicates a potentially hazardous situation with a low level of risk. Failure to observe this warning could result in minor or moderate injury. May also be used with property damage.**



**Potentially hazardous situation. Failure to observe this warning could result in property damage. Is not used for personal injury.**

Safety alert symbol  warns of a potential personal injury hazard.

The signal word (here: DANGER) indicates the level of hazard.

### 1.4. References and symbols

The following references and symbols are used in these instructions:

**Information** The term **Information** preceding the text indicates important notes and information.

 Symbol for CLOSED (valve closed)

 Symbol for OPEN (valve open)

**M ▶ Via the menu to parameter**

Describes the menu path to the parameter. When using the push buttons of local controls, the required parameter can be quickly found on the display. Display texts are shaded in grey: **Display**.

**➔ Result of a process step**

Describes the result of a preceding process step.

## 2. Short description

**Multi-turn actuator** Definition in compliance with EN 15714-2/EN ISO 5210:

A multi-turn actuator is an actuator which transmits torque to a valve for at least one full revolution.

**AUMA multi-turn actuator** Figure 1: AUMA SA 10.2 multi-turn actuator

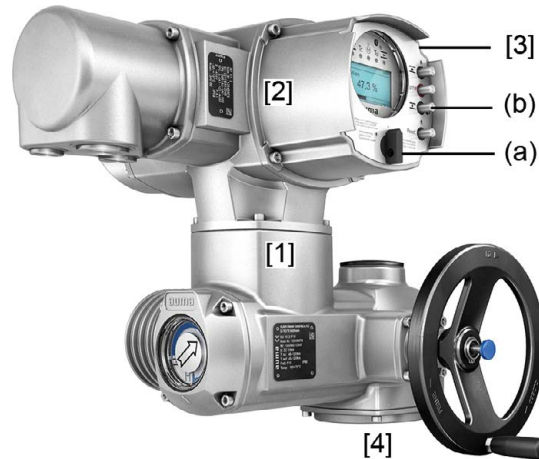

- [1] Multi-turn actuator with motor and handwheel
- [2] Actuator controls
- [3] Local controls with display, (a) selector switch and (b) push button
- [4] Valve connection, e.g. output drive type A

AUMA multi-turn actuators SA 07.2 – SA 16.2/SAR 07.2 – SAR 16.2 are driven by an electric motor. A handwheel is available for setting and emergency operation.

Switching off in end positions may be either by limit or torque seating.

Actuator controls are required to operate or process the actuator signals.

For non-intrusive version (control unit: electromechanical version), limit and torque setting is made via switches within the actuator.

For non-intrusive version (control unit: electronic version), limit and torque setting is made via the actuator controls, neither actuator nor the actuator controls housing have to be opened. For this purpose, the actuator is equipped with an MWG (magnetic limit and torque transmitter), also capable of supplying analogue torque feedback signals/torque indication and analogue position feedback signals/position indication at the actuator controls output.

In combination with output drive type A, the actuator is capable of withstanding thrust.

**Actuator controls** The actuator controls AC 01.2 may be mounted directly to the actuator or separately on a wall bracket.

The actuator can be operated via the push buttons on the local controls of the actuator controls or settings can be made in the actuator controls menu. The display shows information on the actuator as well as the menu settings.

The functions of the actuator controls include standard valve control in OPEN-CLOSE duty, positioning, process control, logging of operating data, diagnostic functions right through control via various interfaces (e.g. fieldbus, Ethernet and HART).

### App and software

Using the **AUMA CDT** software for Windows-based computers (notebooks or tablets) and the **AUMA Assistant App**, actuator data can be uploaded and read, settings can be modified and stored. The connection between computer and AUMA actuator is established wireless via Bluetooth interface. With the **AUMA Cloud**, we provide an interactive platform to collect and assess e.g. detailed device data of all actuators within a plant.

Figure 2: Communication via Bluetooth

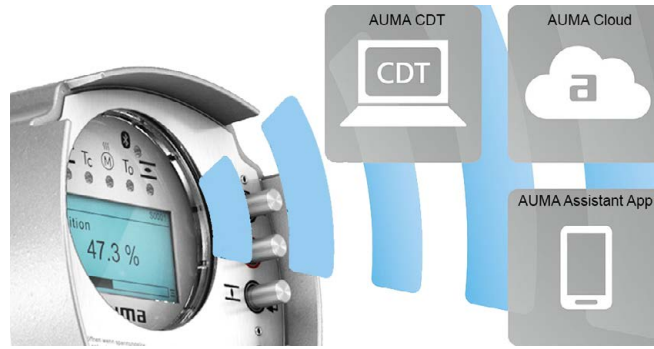

**AUMA CDT**

AUMA CDT is a user-friendly setting and operation program for AUMA actuators.



AUMA CDT software can be downloaded free of charge from our website [www.auma.com](http://www.auma.com).

**AUMA Cloud**

The AUMA Cloud is the driving element of the digital AUMA world, acting as interactive platform for efficient maintenance of AUMA actuators at moderate cost. The AUMA Cloud collects all device data of all actuators within one site and provides a clear overview at a glance. Detailed analysis provides valuable information on potential maintenance requirements. Additional functions foster smooth asset management.



**AUMA Assistant App**

The AUMA Assistant App enables remote setting and remote diagnostics of AUMA actuators via Bluetooth using either smartphone or tablet.

The AUMA Assistant App can be downloaded free of charge from the Play Store (Android) or App Store (iOS).



Figure 3: Link to AUMA Assistant App





### 3. Name plate

Figure 4: Arrangement of name plates

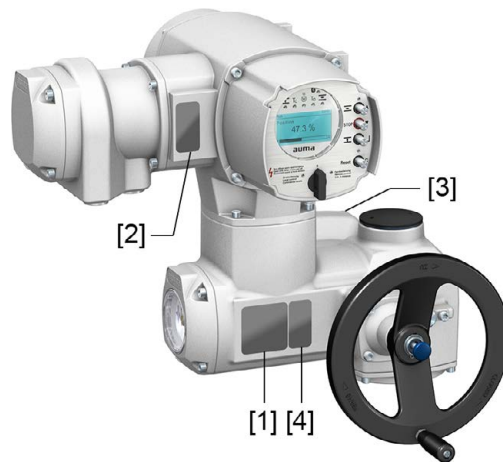

- [1] Actuator name plate
- [2] Actuator controls name plate
- [3] Motor name plate
- [4] Additional plate, e.g. KKS plate (Power Plant Classification System)

#### Actuator name plate

Figure 5: Actuator name plate (example)



**auma** (= manufacturer logo); **CE** (= CE mark)

- [1] Name of manufacturer
- [2] Address of manufacturer
- [3] **Type designation**
- [4] **Order number**
- [5] **Serial number**
- [6] Speed
- [7] Torque range in direction CLOSE
- [8] Torque range in direction OPEN
- [9] Type of lubricant
- [10] Permissible ambient temperature
- [11] Can be assigned as an option upon customer request
- [12] Enclosure protection
- [13] **Data Matrix code**

**Actuator controls name plate**

Figure 6: Name plate for actuator controls (example)

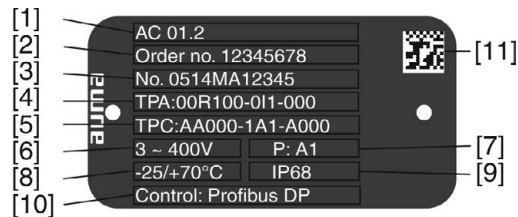

- [1] **Type designation**
- [2] **Order number**
- [3] **Serial number**
- [4] **Actuator terminal plan**
- [5] Actuator controls terminal plan
- [6] Mains voltage
- [7] **AUMA power class for switchgear**
- [8] Permissible ambient temperature
- [9] Enclosure protection
- [10] **Control**
- [11] Data Matrix code

**Motor name plate**

Figure 7: Motor name plate (example)



**auma** (= manufacturer logo); **CE** (= CE mark)

- [1] Motor type
- [2] Motor article number
- [3] Serial number
- [4] Current type, mains voltage
- [5] Rated power
- [6] Rated current
- [7] Type of duty
- [8] Enclosure protection
- [9] Motor protection (temperature protection)
- [10] Insulation class
- [11] Speed
- [12] Power factor cos phi
- [13] Mains frequency
- [14] Data Matrix code

**Descriptions referring to name plate indications**

**Type designation**

Table 1:

Description of type designation (with the example of SA 07.2-F07)			
	07.2	-F10	
			Type <b>SA</b> = Multi-turn actuators for open-close duty Type <b>SAR</b> = Multi-turn actuators for modulating duty
	07.2		Size These instructions apply to sizes 07.2, 07.6, 10.2, 14.2, 14.6, 16.2
		F10	Flange size

Table 2:

Description of actuator controls type designation (with the example of AC 01.2)			
AC	01.2		
AC			Type AC = AUMATIC actuator controls
	01.2		Size 01.2

**Order number**

The product can be identified using this number and the technical data as well as order-related data pertaining to the device can be requested.

Please always state this number for any product inquiries.

On the Internet at <http://www.auma.com> > Service & Support > myAUMA, we offer a service allowing authorised users to download order-related documents such as wiring diagrams and technical data (both in German and English), inspection certificate and the operation instructions when entering the order number.

**Actuator serial number**

Table 3:

Description of serial number (example of 0520MD12345)			
05	20	MD12345	
05			Positions 1+2: Assembly in week = week 05
	20		Positions 3+4: Year of manufacture = 2020
		MD12345	Internal number for unambiguous product identification

**Actuator terminal plan**

Position 9 after **TPA**: Position transmitter version

**I, Q** = MWG (magnetic limit and torque transmitter)

**AUMA power class for switchgear**

The switchgear used in the actuator controls (reversing contactors/thyristors) are classified according to AUMA power classes (e.g. A1, B1, ...). The power class defines the max. permissible rated power (of the motor) the switchgear has been designed for. The rated power (nominal power) of the actuator motor is indicated in kW on the motor name plate. For the assignment of the AUMA power classes to the nominal power of the motor types, refer to the separate electrical data sheets.

For switchgear without assignment to any power classes, the actuator controls name plate does not indicate the power class but the max. rated power in kW.

**Control**

Table 4:

Control examples (indications on actuator controls name plate)	
Input signal	Description
Profibus DP	Control via Profibus DP interface
Profibus DP/24 V DC	Control via Profibus DP interface and control voltage for OPEN-CLOSE control via digital inputs (OPEN, STOP, CLOSE)

**Data Matrix code**

When registered as authorised user, you may use our **AUMA Assistant App** to scan the Data Matrix code and directly access the order-related product documents without having to enter order number or serial number.

Figure 8: Link to AUMA Assistant App:



For further Service & Support, Software/Apps/... refer to [www.auma.com](http://www.auma.com)

## 4. Transport and storage

### 4.1. Transport

**Actuator** For transport to place of installation, use sturdy packaging.



#### Suspended load!

*Death or serious injury.*

- Do NOT stand below suspended load.
- Attach ropes or hooks for the purpose of lifting by hoist only to housing and NOT to handwheel.
- Actuators mounted on valves: Attach ropes or hooks for the purpose of lifting by hoist to valve and NOT to actuator.
- Actuators mounted to gearboxes: Attach ropes or hooks for the purpose of lifting by hoist only to the gearbox using eyebolts and NOT to the actuator.
- Actuators mounted to controls: Attach ropes or hooks for the purpose of lifting by hoist only to the actuator and NOT to the controls.
- Respect total weight of combination (actuator, actuator controls, gearbox, valve)
- Secure load against falling down, sliding or tilting.
- Perform lift trial at low height to eliminate any potential danger e.g. by tilting.

Figure 9: Example: Lifting the actuator



#### Weights

Table 5:

Weight for AC 01.2 actuator controls	
with electrical connection type:	Weight approx. [kg]
AUMA plug/socket connector with screw-type connection	7

Table 6:

<b>Weights for multi-turn actuators SA 07.2 – SA 16.2 / SAR 07.2 – SAR 16.2 with 3-phase AC motors</b>		
Type designation Actuator	Motor type <sup>1)</sup>	Weight <sup>2)</sup>
		approx. [kg]
SA 07.2/ SAR 07.2	VD...	19
	AD...	20
SA 07.6/ SAR 07.6	VD...	20
	AD...	21
SA 10.2/ SAR 10.2	VD...	22
	AD...	25
SA 14.2/ SAR 14.2	VD...	44
	AD...	48
SA 14.6/ SAR 14.6	VD...	46
	AD...	53
SA 16.2/ SAR 16.2	VD...	67
	AD...	83

- 1) Refer to motor name plate
- 2) Indicated weight includes AUMA NORM multi-turn actuator with 3-phase AC motor, electrical connection in standard version, output drive type B1 and handwheel. For other output drive types, heed additional weights.

Table 7:

<b>Weights for multi-turn actuators SA 07.2 – SA 16.2 / SAR 07.2 – SAR 16.2 With 1-phase AC motors</b>		
Type designation Actuator	Motor type <sup>1)</sup>	Weight <sup>2)</sup>
		approx. [kg]
SA 07.2/ SAR 07.2	VB...	21
	VE...	21
	AE...	28
SA 07.6/ SAR 07.6	VB...	21
	VE...	25
	AE...	28
	AC...	37
SA 10.2/ SAR 10.2	VE...48-4...	28
	VE...48-2...	31
	AC... 56-4...	40
	AC... 56-2...	43
SA 14.2/ SAR 14.2	VE...	59
	VC...	61
	AC...	63
SA 14.6/ SAR 14.6	VE...	63
	VC...	66

- 1) Refer to motor name plate
- 2) Indicated weight includes AUMA NORM multi-turn actuator with 1-phase AC motor, electrical connection in standard version, output drive type B1 and handwheel. For other output drive types, heed additional weights.

Table 8:

<b>Weights for multi-turn actuators SA 07.2 – SA 16.2 / SAR 07.2 – SAR 16.2 With DC motors</b>		
Type designation Actuator	Motor type <sup>1)</sup>	Weight <sup>2)</sup> approx. [kg]
SA 07.2/ SAR 07.2	FN... 63-...	29
	FN... 71-...	32
SA 07.6/ SAR 07.6	FN... 63-...	30
	FN... 80-...	44
SA 10.2/ SAR 10.2	FN... 63-...	33
	FN... 71-...	36
	FN... 90-...	56
SA 14.2/ SAR 14.2	FN... 71-... / FN... 80-...	68
	FN... 90-...	100
SA 14.6/ SAR 14.6	FN... 80-... / FN... 90-...	76
	FN... 112-...	122
SA 16.2/ SAR 16.2	FN... 100-...	123

1) Refer to motor name plate

2) Indicated weight includes AUMA NORM multi-turn actuator with DC motor, electrical connection in standard version, output drive type B1 and handwheel. For other output drive types, heed additional weights.

Table 9:

<b>Weights for output drive type</b>		
Type designation	Flange size	[kg]
A 07.2	F07	1.1
	F10	1.3
A 10.2	F10	2.8
A 14.2	F14	6.8
A 16.2	F16	11.7

Table 10:

<b>Weights for output drive type</b>		
Type designation	Flange size	[kg]
AF 07.2	F10	5.2
AF 07.6	F10	5.2
AF 10.2	F10	5.5
AF 14.2	F14	13.7
AF 16.2	F16	23

## 4.2. Storage

**NOTICE**

**Danger of corrosion due to inappropriate storage!**

- Store in a well-ventilated, dry room.
- Protect against floor dampness by storage on a shelf or on a wooden pallet.
- Cover to protect against dust and dirt.
- Apply suitable corrosion protection agent to uncoated surfaces.

**NOTICE**

---

**Risk of damage due to excessively low temperatures!**

- Actuator controls may only be stored permanently down to  $-30\text{ }^{\circ}\text{C}$ .
  - On request, actuators controls may be transported in specific cases and for short duration at temperatures down to  $-60\text{ }^{\circ}\text{C}$ .
- 

**Long-term storage**

For long-term storage (more than 6 months), observe the following points:

1. Prior to storage:  
Protect uncoated surfaces, in particular the output drive parts and mounting surface, with long-term corrosion protection agent.
2. At an interval of approx. 6 months:  
Check for corrosion. If first signs of corrosion show, apply new corrosion protection.



## 5. Assembly

### 5.1. Mounting position

When using grease as lubricant, the product described herein can be operated in any mounting position.

When using oil instead of grease within the actuator gear housing, perpendicular mounting position is specified whereby the flange is pointing downward. The type of lubricant used is indicated on the actuator name plate (short designation **F**...= grease; **O**...= oil).

### 5.2. Handwheel fitting

To avoid transport damage, handwheels are supplied separately as appropriate. In this instance, the handwheel must be mounted prior to commissioning.

Figure 10: Handwheel

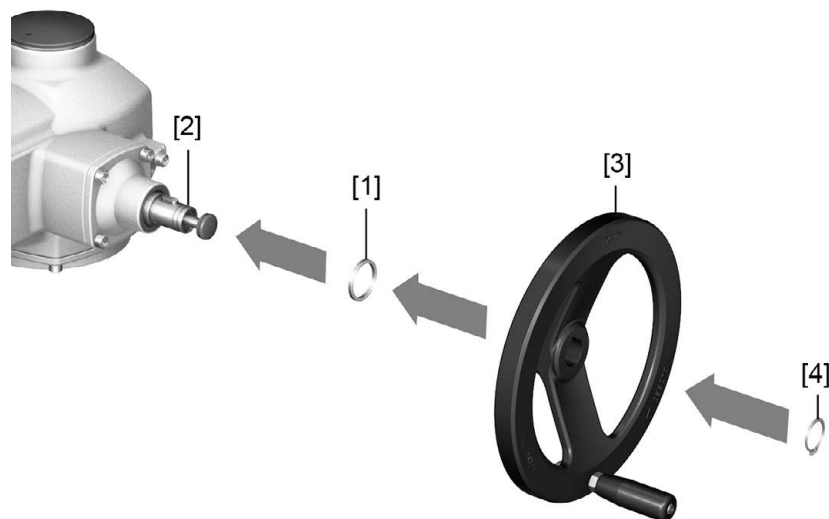

- [1] Spacer
- [2] Input shaft
- [3] Handwheel
- [4] Retaining ring

- How to proceed**
1. If required, fit spacer [1] on input shaft [2].
  2. Slip handwheel [3] onto input shaft.
  3. Secure handwheel [3] with retaining ring [4].

**Information:** The retaining ring [4] (together with these operation instructions) is stored in a weatherproof bag, which is attached to the device prior to delivery.

### 5.3. Mount actuator to valve

**NOTICE**

**Corrosion due to damage to paint finish and condensation!**

- Touch up damage to paint finish after work on the device.
- After mounting, connect the device immediately to electrical mains to ensure that heater minimises condensation.

### 5.3.1. Overview of output drive types

Table 11: Overview on output drive types

Valve attachment	Application	Description	Assembly
A	<ul style="list-style-type: none"> <li>for rising, non-rotating valve stem</li> <li>capable of withstanding thrust</li> <li>not appropriate for radial forces</li> </ul>	⇒ page 18, Output drive type A	⇒ page 19, Multi-turn actuator with output drive type A: mount
B, B1 – B4 C D E	<ul style="list-style-type: none"> <li>for rotating, non-rising valve stem</li> <li>not capable of withstanding thrust</li> </ul>	⇒ page 22, Output drive types B/C/D and E	⇒ page 23, Multi-turn actuator with output drive type B: mount

### 5.3.2. Output drive type A

Figure 11: Output drive type A

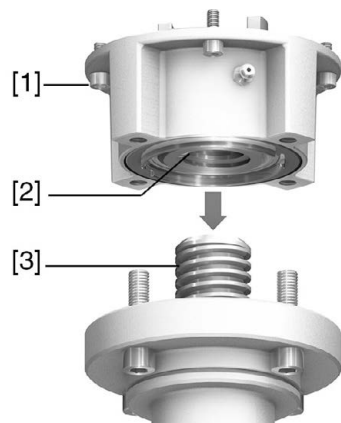

- [1] Output mounting flange
- [2] Stem nut
- [3] Valve stem

**Short description** Output drive type A consisting of output mounting flange [1] with axial bearing stem nut [2]. The stem nut transmits the torque from the actuator hollow shaft to the valve stem [3]. Output drive type A can withstand thrusts.

To adapt the actuators to available output drive types A with flanges F10 and F14 (year of manufacture 2009 and earlier), an adapter is required. The adapter can be ordered from AUMA.

### 5.3.2.1. Multi-turn actuator with output drive type A: mount

1. If output drive type A is already mounted to the multi-turn actuator: Loosen screws [3] and remove output drive type A [2].

Figure 12: Multi-turn actuator with output drive type A

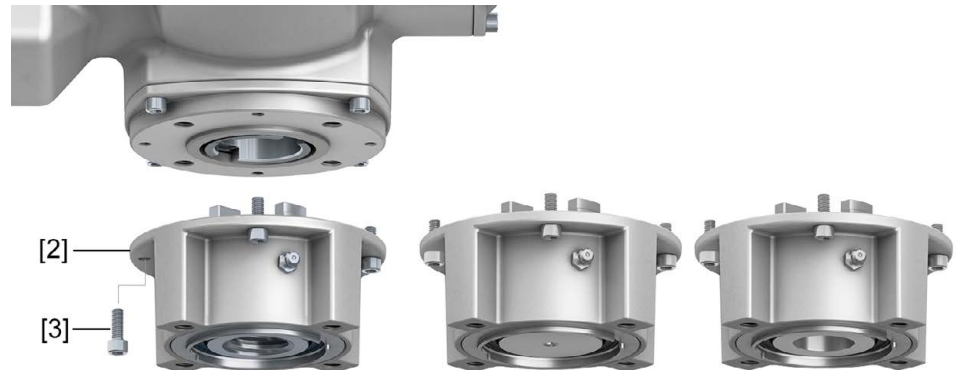

- [1] Multi-turn actuator  
[2] Output drive type A, from left to right:  
with finish-machined, unbored and pilot bore stem nut  
[3] Screws to multi-turn actuator

**Information** For an unbored or pilot bore stem nut, the stem nut must be finish machined prior to mounting valve stem and prior to performing the following steps. → [page 21, Stem nut for output drive type A: finish machining](#)

2. Apply a small quantity of grease to the valve stem.
3. Place output drive type A [2] on valve stem and turn until it is [4] flush on the valve flange.
4. Turn output drive type A [2] until alignment of the fixing holes.
5. Fasten screws [5] between valve and output drive type A [2] without completely tightening them.

Figure 13:

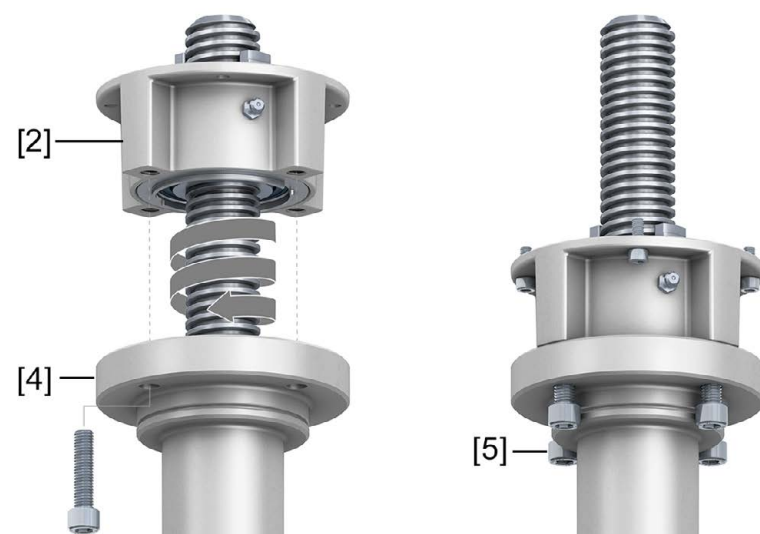

6. Fit multi-turn actuator on the valve stem so that the stem nut dogs engage into the output drive sleeve.

Figure 14:

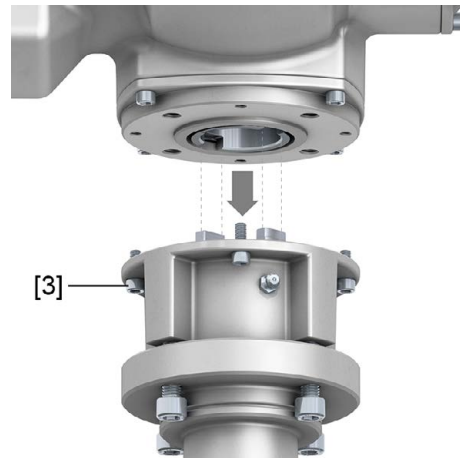

- ➔ The flanges are flush with each other if properly engaged.
7. Adjust multi-turn actuator until alignment of the fixing holes.
  8. Fasten multi-turn actuator with screws [3].
  9. Fasten screws [3] crosswise with a torque according to table.

Table 12:

Tightening torques for screws	
Threads	Tightening torque [Nm]
	Strength class A2-80/A4-80
M8	24
M10	48
M16	200
M20	392

10. Turn multi-turn actuator with handwheel in direction OPEN until valve flange [4] and output drive type A [2] are firmly placed together.

Figure 15:

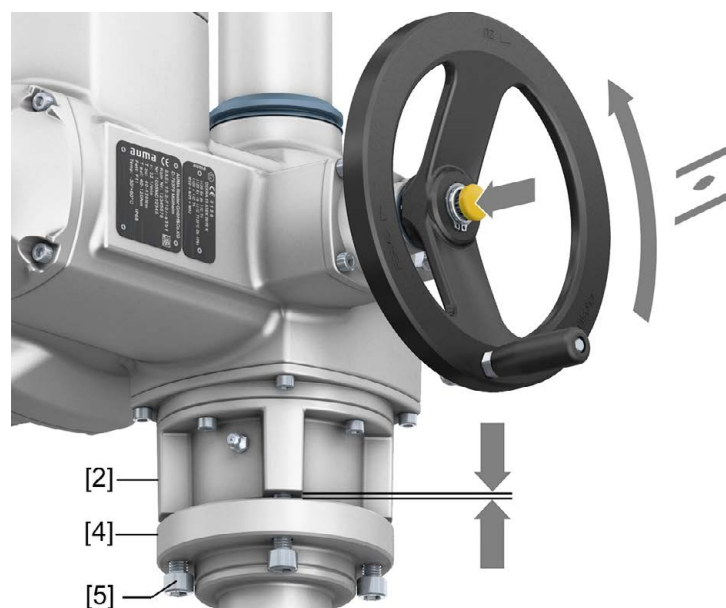

11. Tighten screws [5] between valve and output drive type A crosswise applying a torque according to table.

### 5.3.2.2. Stem nut for output drive type A: finish machining

This working step is only required if stem nut is supplied unbored or with pilot bore.

**Information** For exact product version, please refer to the order-related technical data sheet or the AUMA Assistant App.

Figure 16: Output drive type A

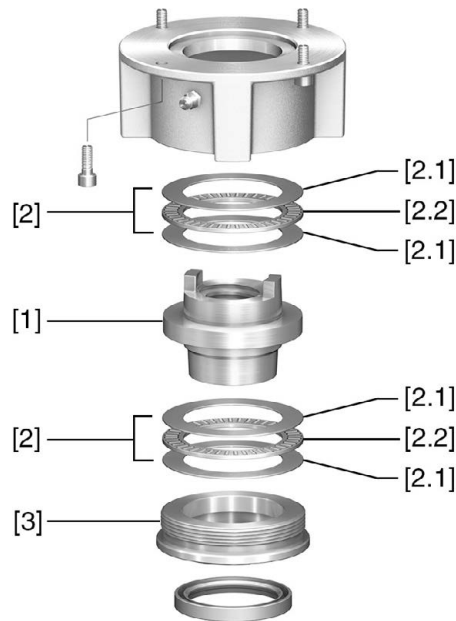

- [1] Stem nut
- [2] Axial needle roller bearing
- [2.1] Axial bearing washer
- [2.2] Axial needle roller and cage assembly
- [3] Spigot ring

- Procedure**
1. Remove spigot ring [3] from output drive.
  2. Remove stem nut [1] together with axial needle roller bearings [2].
  3. Remove axial bearing washers [2.1] and axial needle roller and cage assemblies [2.2] from stem nut [1].
  4. Drill and bore stem nut [1] and cut thread.
  5. Clean the machined stem nut [1].
  6. Apply sufficient Lithium soap EP multi-purpose grease to axial needle roller and cage assemblies [2.2] and axial bearing washers [2.1], ensuring that all hollow spaces are filled with grease.
  7. Place greased axial needle roller and cage assemblies [2.2] and axial bearing washers [2.1] onto stem nut [1].
  8. Re-insert stem nut [1] with axial needle roller bearings [2] into output drive.
  9. Screw in spigot ring [3] until it is firm against the shoulder.

**5.3.3. Output drive types B/C/D and E**

Figure 17: Mounting principle

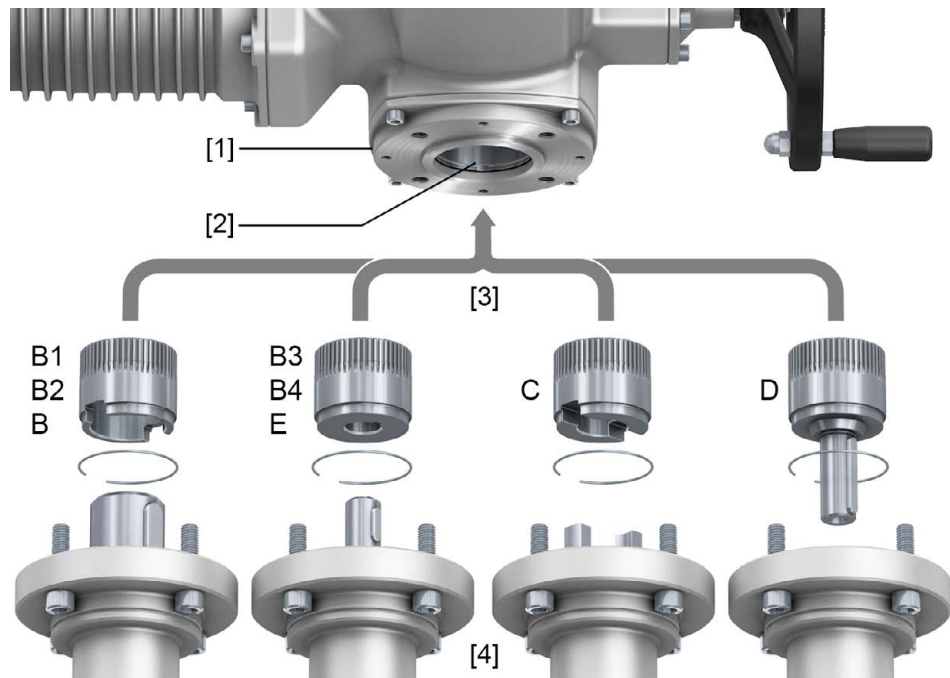

- [1] Flange multi-turn actuator (e.g. F07)
- [2] Hollow shaft
- [3] Output drive sleeve (illustration examples)
- [4] Gearbox/valve shaft

**Short description** Connection between hollow shaft and valve or gearbox via output drive sleeve fixed to the hollow shaft of the multi-turn actuator via retaining ring.

When exchanging the output drive sleeve, later retrofitting to a different output drive type is possible

- Output drive type B/E:  
Output drive sleeve with bore according to DIN 3210
- Output drive types B1/B3:  
Output drive sleeve with bore according to EN ISO 5210
- Output drive types B2/B4:  
Output drive sleeve with bore according to customer order  
B4 including special bores like bores without keyway, square bore, hexagon bore, internal splines
- Output drive type C:  
Output drive sleeve with dog coupling according to EN ISO 5210 or DIN 3338
- Output drive type D:  
Shaft end with key according to EN ISO 5210 or DIN 3210

**Information** Spigot at valve flanges should be loose fit.

**5.3.3.1. Multi-turn actuator with output drive type B: mount**

Figure 18: Mounting output drive types B

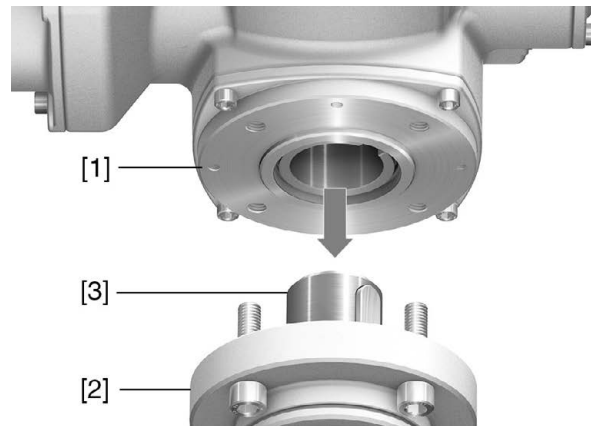

- [1] Multi-turn actuator
- [2] Valve/gearbox
- [3] Valve/gearbox shaft

**Procedure**

1. Check if mounting flanges fit together.
2. Check if output drive of multi-turn actuator [1] matches the output drive of valve/gearbox or valve/gearbox valve shaft [2/3].
3. Apply a small quantity of grease to the valve or gearbox shaft [3].
4. Place multi-turn actuator [1] and ensure that the spigot fits uniformly in the recess and that the mounting faces are in complete contact.
5. Fasten multi-turn actuator with screws according to table.  
**Information:** We recommend applying liquid thread sealing material to the screws to avoid contact corrosion.
6. Fasten screws crosswise to a torque according to table.

Table 13:

Tightening torques for screws	
Threads	Tightening torque [Nm]
	Strength class A2-80/A4-80
M8	24
M10	48
M16	200
M20	392

**5.4. Accessories for assembly**

**5.4.1. Stem protection tube for rising valve stem**

Figure 19: Assembly of the stem protection tube

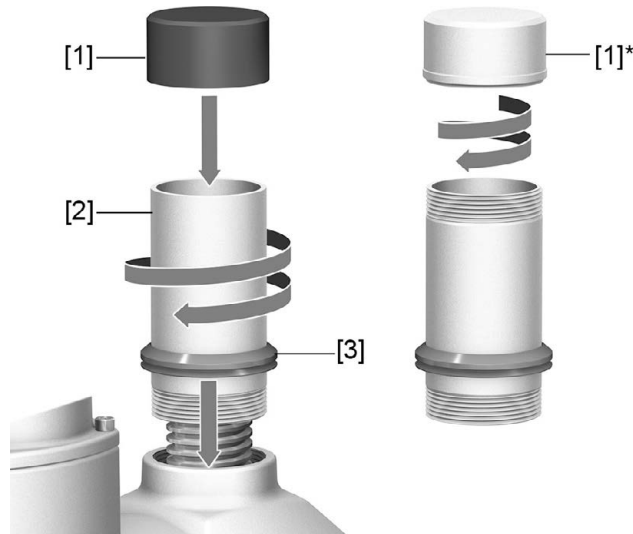

- [1] Protective cap for stem protection tube (fitted)
- [1]\* Option: Protective cap made of steel (screwed)
- [2] Stem protection tube
- [3] V-seal

**Procedure**

1. Seal all threads with hemp, Teflon tape, sealing agent or thread sealing material.
2. Screw stem protection tube [2] into thread and tighten it firmly.  
**Information:** For stem protection tubes made of two or more segments, all parts have to be thoroughly screwed together.

Figure 20: Protection tube made of segments with threaded sleeves (>900 mm)

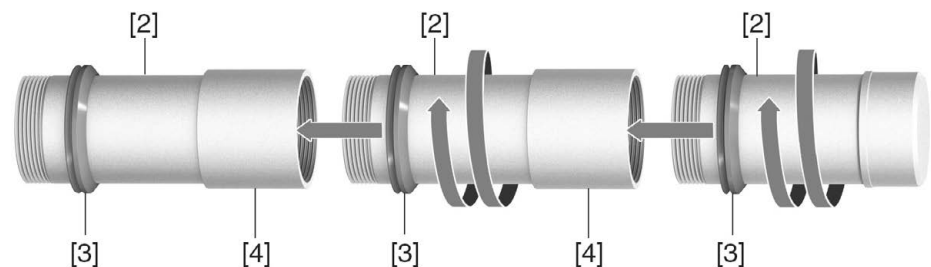

- [2] Segment of stem protection tube
- [3] V-seal
- [4] Threaded sleeve

3. Push down the sealing ring [3] onto the housing.  
**Information:** For mounting segments, push down seals of segments down to the sleeve (connecting piece).
4. Check whether protective cap [1] for stem protection tube is available, in perfect condition and tightly placed on or screwed to the tube.

**NOTICE**

**Risk of bending or oscillation of protection tubes exceeding a length of 2 m!**

*Risk of damage at stem and/or protection tube.*

→ Secure protection tubes exceeding 2 m by an appropriate support.



## 5.5. Mounting positions of local controls

Figure 21: Mounting positions



The mounting position of the local controls is implemented according to the order. If, after mounting the actuator to the valve or the gearbox on site, the local controls are in an unfavourable position, the mounting position can be changed at a later date. Four mounting positions shifted by respectively 90° are possible (by maximum 180° into one direction).

### 5.5.1. Mounting positions: modify



**DANGER**

#### **Electric shock due to presence of hazardous voltage!**

*Failure to observe this warning results in death or serious injury.*

→ Disconnect device from the mains before opening.



**NOTICE**

#### **Electrostatic discharge ESD!**

*Risk of damage to electronic components.*

→ Earth both operators and devices.

1. Loosen screws and remove the local controls.
2. Check whether O-ring is in good condition, correctly insert O-ring.
3. Turn local controls into new position and re-place.



**NOTICE**

#### **Cable damage due to twisting or pinching!**

*Risk of functional failures.*

→ Turn local controls by a maximum of 180°.

→ Carefully assemble local controls to avoid pinching the cables.

4. Fasten screws evenly crosswise.

## 6. Electrical connection

### 6.1. Basic information



#### Electric shock due to presence of hazardous voltage!

*Failure to observe this warning can result in death, serious injury, or property damage.*

- The electrical connection must be carried out exclusively by suitably qualified personnel.
- Prior to connection, observe basic information contained in this chapter.
- After connection but prior to applying the voltage, observe the <Commissioning> and <Test run> chapters.

#### Wiring diagram/terminal plan

The pertaining wiring diagram/terminal plan (in German or English) is attached to the device in a weather-proof bag, together with these operation instructions. It can also be requested from AUMA (state order number, refer to name plate) or downloaded directly from the Internet (<http://www.auma.com>).

#### Permissible networks (supply networks)

The actuators are suitable for use in TN and TT networks with directly grounded star point for nominal voltages up to maximum 690 V AC. Use in IT network is permissible for nominal voltages up to maximum 600 V AC. For IT network, a suitable, approved insulation monitor measuring the pulse code is required.

#### Current type, mains voltage, mains frequency

Type of current, mains voltage and mains frequency must match the data on the actuator controls and motor name plates. Also refer to chapter <Identification>/<Name plate>.

Figure 22: Motor name plate (example)

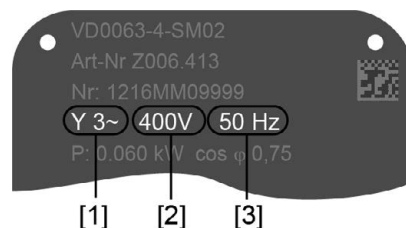

- [1] Type of current
- [2] Mains voltage
- [3] Mains frequency

#### External supply of the electronics

For external electronics supply, the power supply of actuator controls must have an enhanced isolation against mains voltage in compliance with IEC 61010-1 and the output power has to be limited to 150 VA in compliance with IEC 61010-1.

#### Protection and sizing on site

For short-circuit protection and for disconnecting the actuator from the mains, fuses and disconnect switches have to be provided by the customer.

The current values for sizing the protection can be derived from the current consumption of the motor (refer to motor name plate) plus the current consumption of actuator controls.

We recommend adapting the switchgear sizing to the max. current ( $I_{max}$ ) and selecting and setting the overcurrent protection device in compliance with the indications in the electrical data sheet.

Table 14:

Current consumption of actuator controls		
Mains voltage	Max. current consumption	
Permissible variation of the mains voltage	±10 %	±30 %
100 to 120 V AC	750 mA	1,200 mA
208 to 240 V AC	400 mA	750 mA
380 to 500 V AC	250 mA	400 mA
515 to 690 V AC	200 mA	400 mA

Table 15:

Maximum permissible protection		
Switchgear (switchgear with power class) <sup>1)</sup>	Rated power	max. protection
Reversing contactor A1	up to 1.5 kW	16 A (gL/gG)
Reversing contactor A2	up to 7.5 kW	32 A (gL/gG)
Reversing contactor A3	up to 15 kW	63 A (gL/gG)
Thyristor B1	up to 1.5 kW	16 A (g/R) I <sup>2</sup> t<1,500A <sup>2</sup> s
Thyristor B2	up to 3 kW	32 A (g/R) I <sup>2</sup> t<1,500A <sup>2</sup> s
Thyristor B3	up to 5.5 kW	63 A (g/R) I <sup>2</sup> t<5,000A <sup>2</sup> s

1) The AUMA power class (A1, B1, ...) is indicated on the actuator controls name plate

Consider the motor starting current (I<sub>A</sub>) (refer to electrical data sheet) when selecting the circuit breaker. We recommend tripping characteristics D or K for circuit breakers in accordance with IEC 60947-2. For controls equipped with thyristors, we recommend safety fuses instead of circuit breakers. However, the use of circuit breakers is basically permitted.

We recommend refraining from using residual current devices (RCD). However, if an RCD is used within the mains, the residual current device must be of type B.

For actuator controls equipped with a heating system and external electronics power supply, the fuses for the heating system have to be provided by the customer (refer to wiring diagram F4 ext.)

Table 16:

Fuse for heating system		
Designation in wiring diagram = F4 ext.		
External power supply	115 V AC	230 V AC
Fuse	2 A T	1 A T

If actuator controls are mounted separately from actuator (actuator controls on wall bracket): Consider length and cross section of connecting cable when defining the protection required.

**Potential of customer connections  
 Safety standards**

Refer to Technical data for options of isolated potentials.

Safety measures and safety equipment must comply with the respectively valid national on site specifications. All externally connected devices shall comply with the relevant safety standards applicable for the place of installation.

**Connecting cables, cable glands, reducers, blanking plugs**

- We recommend using connecting cables and connecting terminals according to rated current (I<sub>N</sub>) (refer to motor name plate or electrical data sheet).
- For device insulation, appropriate (voltage-proof) cables must be used. Specify cables for the highest occurring rated voltage.
- To avoid contact corrosion, we recommend the use of sealing agents for cable glands and blanking plugs made of metal.
- Use connecting cable with appropriate minimum rated temperature.

- For connecting cables exposed to UV radiation (outdoor installation), use UV resistant cables.
- For the connection of position transmitters, screened cables must be used.

**Cable installation in accordance with EMC**

Signal and fieldbus cables are susceptible to interference. Motor cables are interference sources.

- Lay cables being susceptible to interference or sources of interference at the highest possible distance from each other.
- The interference immunity of signal and fieldbus cables increases if the cables are laid close to the earth potential.
- If possible, avoid laying long cables and make sure that they are installed in areas being subject to low interference.
- Avoid parallel paths with little cable distance of cables being either susceptible to interference or interference sources.

**Fieldbus cable**

Table 17:

<b>Cable recommendation</b>	
Only cables complying with IEC 61158 or IEC 61784, cable type A, may be used for Profibus DP wiring.	
Impedance	135 to 165 Ohm, at a measurement frequency between 3 and 20 MHz
Cable capacity	< 30 pF per metre
Wire diameter	> 0.64 mm
Cross section	> 0.34 mm <sup>2</sup> , corresponds to AWG 22
Loop resistance	< 110 Ohm per km
Screening	CU shielding braid or shielding braid and shielding foil

**Prior to installation, please note:**

- Connect maximum 32 devices to one segment.
- If more devices are to be connected:
  - Allot devices to different segments.
  - Connect segments using repeaters.
- Install fieldbus cables at a distance of minimum 20 cm to other cables.
- If possible, fieldbus cables should be laid in a separate, conductive, and earthed cable tray.
- Ensure absence of equipotential earth bonding differences between the individual devices at fieldbus (perform an equipotential earth bonding).

Baud rate [kbit/s]	≥ 93.75	187.5	500	1,500
Maximum segment length [m]	1,200	1,000	400	200

**6.2. SD electrical connection (AUMA plug/socket connector)**

Figure 23: SD electrical connection

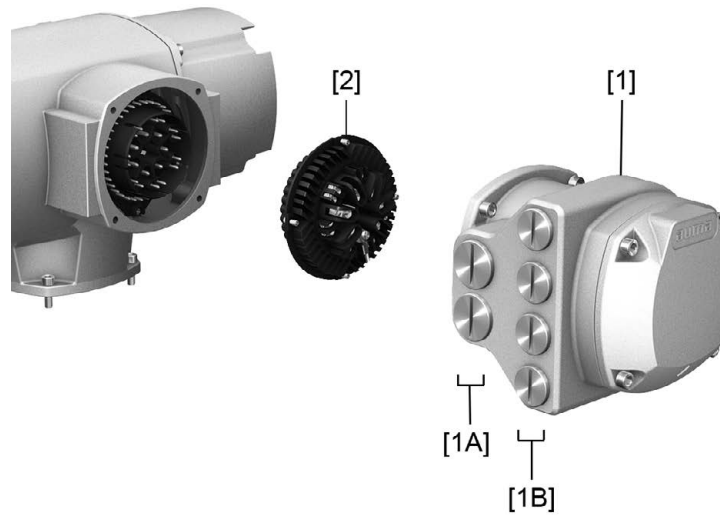

- [1] Terminal compartment (in cover)
- [1A] Cable entries for mains connection (power and control contacts)
- [1B] Cable entries for fieldbus cables
- [2] Socket carrier with screw-type terminals

**Short description**

Plug-in electrical connection with screw-type terminals for power and control contacts. Control contacts also available as crimp-type connection as an option.

SD version. For power and control cable connection, remove the AUMA plug/socket connector and the socket carrier from terminal compartment. Removing the cover is sufficient for connecting the fieldbus cables.

**Technical data**

Table 18:

Electrical connection via AUMA plug/socket connector		
	Power contacts	Control contacts
No. of contacts max.	6 (3 equipped) + protective earth conductor (PE)	50 pins/sockets
Designation	U1, V1, W1, U2, V2, W2, PE	1 to 50
Connection voltage max.	750 V	250 V
Rated current max.	25 A	16 A
Type of customer connection	Screw connection	Screw connection, crimp-type (option)
Connection diameter max.	6 mm <sup>2</sup> (flexible) 10 mm <sup>2</sup> (solid)	2.5 mm <sup>2</sup> (flexible or solid)

**Information**

For some special motors, the connection of the power terminals (U1, V1, W1, U2, V2, W2) is **not** performed via the AUMA plug/socket connector but via a terminal board directly at the motor.

**6.2.1. Terminal compartment (for mains connection): open**

Figure 24: Open mains terminal compartment

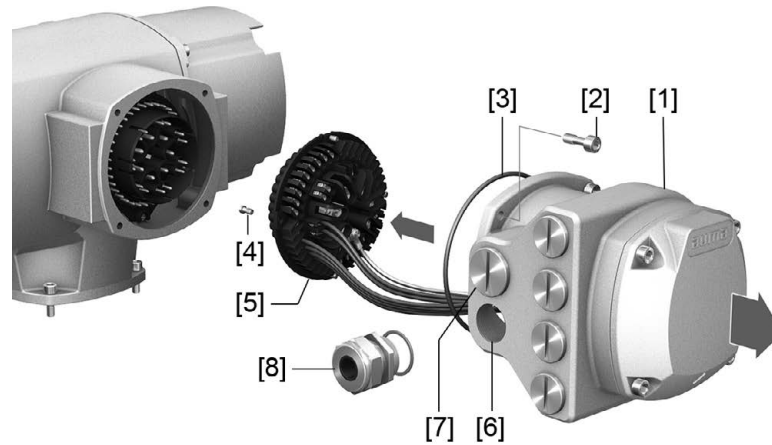

- [1] Connection housing
- [2] Screws for frame
- [3] O-ring
- [4] Screws for socket carrier
- [5] Socket carrier
- [6] Cable entries for mains connection (power and control contacts)
- [7] Blanking plug
- [8] Cable gland (not included in delivery)

**Information** Fieldbus operation is **not** interrupted when removing the connection housing [1].

**Electric shock due to presence of hazardous voltage!**

*Failure to observe this warning results in death or serious injury.*

→ Disconnect device from the mains before opening.

1. Loosen screws [2] and remove connection housing [1].
2. Loosen screws [4] and remove socket carrier [5] from connection housing [1].
3. Insert cable glands [8] suitable for connecting cables.
- ➔ The enclosure protection IP... stated on the name plate is only ensured if suitable cable glands are used.

Figure 25: Example: Name plate for enclosure protection IP68

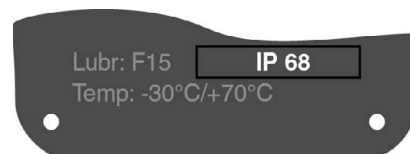

4. Seal unused cable entries [6] with suitable blanking plugs [7].

**Information** Fieldbus connection can be accessed separately from the mains connection (refer to <Fieldbus terminal compartment: open>.

**6.2.2. Cable connection**

Table 19:

Terminal cross sections and terminal tightening torques		
Designation	Terminal cross sections	Tightening torques
Power contacts (U1, V1, W1, U2, V2, W2)	1.0 – 6 mm <sup>2</sup> (flexible) 1.5 – 10 mm <sup>2</sup> (solid)	1.2 – 1.5 Nm
Protective earth connection ⊕ (PE)	1.0 – 6 mm <sup>2</sup> (flexible) with ring lugs 1.5 – 10 mm <sup>2</sup> (solid) with loops	1.2 – 2.2 Nm
Control contacts (1 to 50)	0.25 – 2.5 mm <sup>2</sup> (flexible) 0.34 – 2.5 mm <sup>2</sup> (solid)	0.5 – 0.7 Nm

1. Remove cable sheathing.
2. Insert the wires into the cable glands.
3. Fasten cable glands with the specified torque to ensure required enclosure protection.
4. Strip wires.  
→ Controls approx. 6 mm, motor approx. 10 mm
5. For flexible cables: Use wire end sleeves according to DIN 46228.
6. Connect cables according to order-related wiring diagram.



**In case of a fault: Hazardous voltage while protective earth conductor is NOT connected!**

*Risk of electric shock.*

- Connect all protective earth conductors.
- Connect PE connection to external protective earth conductor of connecting cables.
- Start running the device only after having connected the protective earth conductor.

7. Tighten PE conductors firmly to PE connection using ring lugs (flexible cables) or loops (solid cables).

Figure 26: Protective earthing

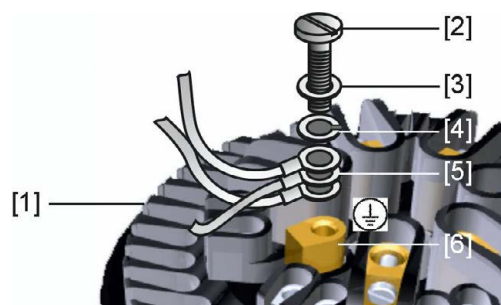

- [1] Socket carrier
- [2] Screw
- [3] Washer
- [4] Lock washer
- [5] Protective earth with ring lugs/loops
- [6] Protective earthing, symbol: ⊕

8. For shielded cables: Link the cable shield end via the cable gland to the housing (earthing).

**6.2.3. Terminal compartment (for mains connection): close**

Figure 27: Close mains terminal compartment

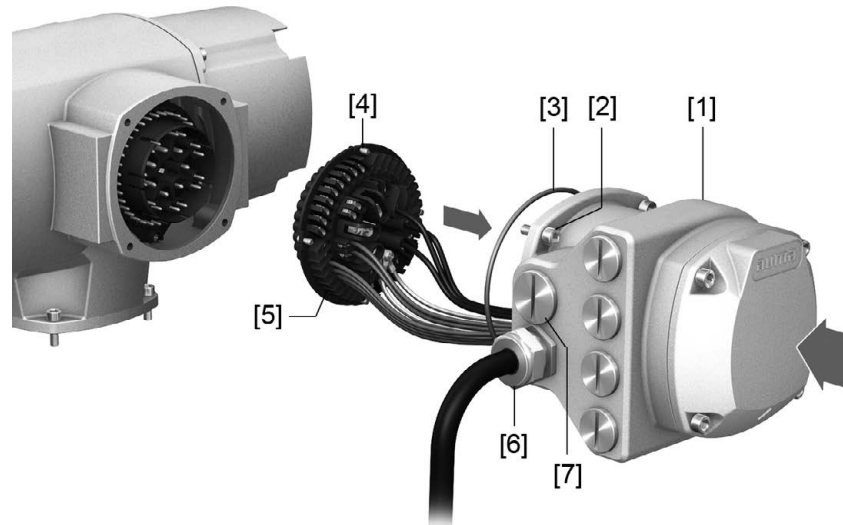

- [1] Connection housing
- [2] Screws for connection housing
- [3] O-ring
- [4] Screws for socket carrier
- [5] Socket carrier
- [6] Cable gland (not included in delivery)
- [7] Blanking plug

**Short-circuit due to pinching of cables!**

*Risk of electric shock and functional failures.*

→ Carefully fit socket carrier to avoid pinching the cables.

1. Insert the socket carrier [5] into the connection housing [1] and fasten with screws [4].
2. Clean sealing faces of connection housing [1] and housing.
3. Check whether O-ring [3] is in good condition, replace if damaged.
4. Apply a thin film of non-acidic grease (e.g. petroleum jelly) to the O-ring and insert it correctly.
5. Fit connection housing [1] and fasten screws [2] evenly crosswise.
6. Fasten cable glands and blanking plugs applying the specified torque to ensure the required enclosure protection.



### 6.2.4. Fieldbus terminal compartment: open

Figure 28: Open cover to fieldbus terminal compartment

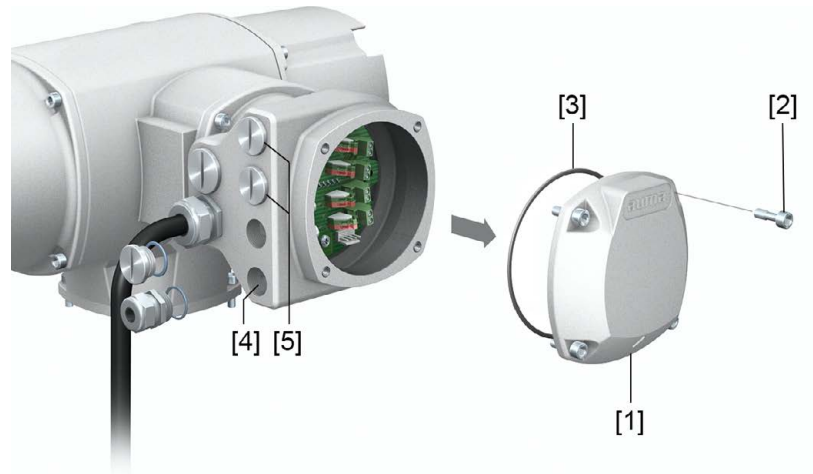

- [1] Cover (fieldbus terminal compartment)
- [2] Screws for cover
- [3] O-ring
- [4] Cable entries for fieldbus cables
- [5] Blanking plug

The AUMA plug/socket connector is equipped with a connection board for connecting the fieldbus cables. When removing the cover [1], the connection board is easily accessible.



#### Electric shock due to presence of hazardous voltage!

*Failure to observe this warning results in death or serious injury.*

→ Disconnect device from the mains before opening.



#### Electrostatic discharge ESD!

*Risk of damage to electronic components.*

→ Earth both operators and devices.

1. Loosen screws [2] and remove cover [1].
2. Insert cable glands suitable for fieldbus cables.
- ➔ The enclosure protection IP... stated on the name plate is only ensured if suitable cable glands are used.

Figure 29: Example: Name plate for enclosure protection IP68

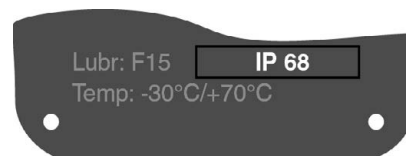

3. Seal unused cable entries with suitable plugs.

6.2.5. Fieldbus cables: connect

RS-485 connection boards

Table 20:

Variant	Overvoltage protection up to 4 kV	AUMA art. no. on label <sup>1)</sup>
1 channel (standard)	No	Z071.720/02
1 channel	Yes	Z071.720/04
2 channel for redundancy	No	Z071.720/03
2 channel for redundancy	Yes	Z071.720/05

1) Label with article number on connection board

Figure 30: Variants of connection boards

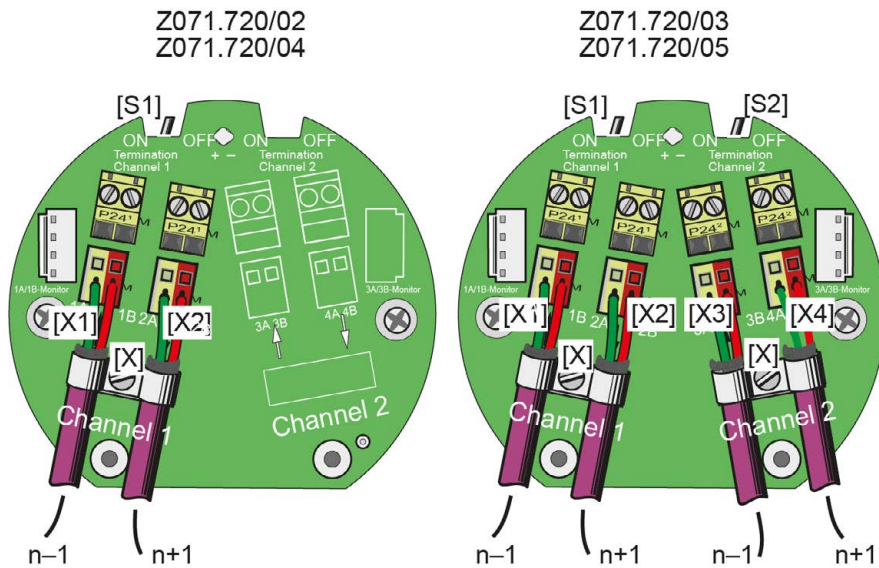

n-1 Fieldbus cable from previous device (input)

n+1 Fieldbus cable to next device (output)

[X] Shielding clamp

[X...] Terminal designation (X1, X2, X3, X4) according to wiring diagram

[S1/2] "Termination" switch for fieldbus termination

Table 21:

Functions of switches [S1] and [S2] <sup>1)</sup>		
[S1]	ON	Fieldbus termination channel 1 ON
	OFF	Fieldbus termination channel 1 OFF
[S2]	ON	Fieldbus termination channel 2 ON (option)
	OFF	Fieldbus termination channel 2 OFF (option)

1) Upon delivery, the switches [S1] and [S2] are set to position OFF.

Cable connection

1. Always link A connections to green wire and B connections to red wire.
2. If the actuator is the final fieldbus device in the fieldbus segment:
  - 2.1 Switch on the termination resistor for channel 1 using switch [S1] (position ON).
  - 2.2 For redundancy: Switch on the termination resistor for channel 2 using switch [S2] (position ON).
 

**Information:** As soon as the termination resistors are switched on, the connection to the next fieldbus device is automatically interrupted to avoid multiple terminations.
3. Connect cable shield largely to shielding clamp [X].

### 6.2.6. Fieldbus terminal compartment: close

Figure 31: Close fieldbus terminal compartment

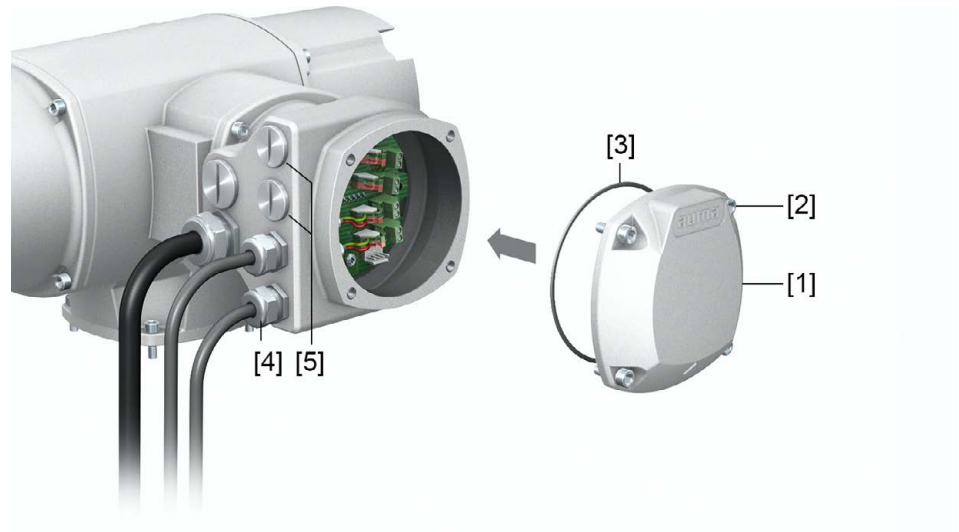

- [1] Cover (fieldbus terminal compartment)
- [2] Screws for cover
- [3] O-ring
- [4] Cable entries for fieldbus cables
- [5] Blanking plug

1. Clean sealing faces of cover [1] and housing.
2. Apply a thin film of non-acidic grease (e.g. petroleum jelly) to the sealing faces.
3. Check whether O-ring [3] is in good condition, correctly insert O-ring.
4. Fit cover [1] and fasten screws [2] evenly crosswise.
5. Fasten cable glands and blanking plugs applying the specified torque to ensure the required enclosure protection.

### 6.3. Accessories for electrical connection

#### 6.3.1. Actuator controls on wall bracket

**Design** Figure 32: Design principle with wall bracket (example)

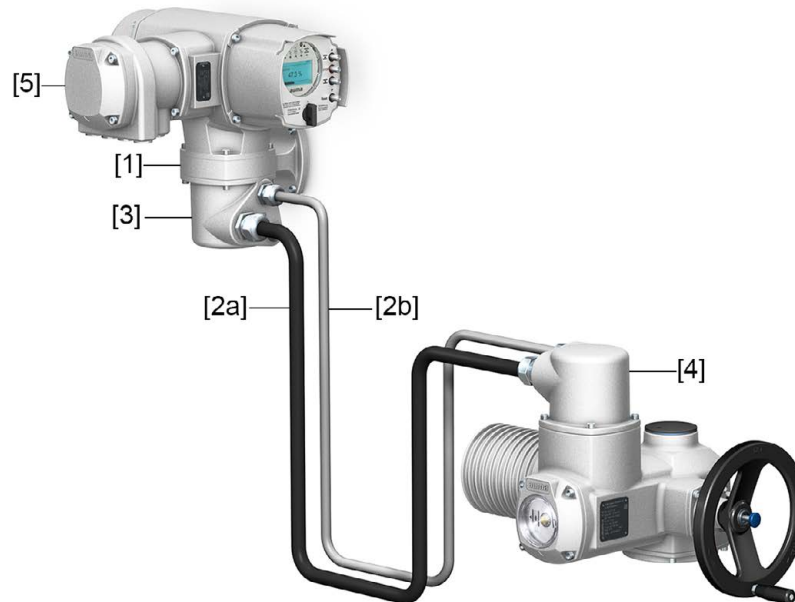

- [1] Wall bracket
- [2a] Motor connection/motor control
- [2b] Feedback signals from actuator
- [3] Electrical connection of wall bracket (XM)
- [4] Electrical connection of actuator (XA)
- [5] Electrical connection of actuator controls (XK)

**Application** The wall bracket allows separate mounting of actuator controls and actuator.

- If the actuator cannot be accessed safely.
- If the actuator is subjected to high temperatures.
- In case of heavy vibration of the valve.

#### Information on installation with wall bracket

- The permissible cable length between actuator controls on wall bracket and the actuator amounts to 100 m maximum.
- We recommend using an AUMA “LSW” cable set.
- If the AUMA cable set is not used:
  - Use suitable flexible and screened connecting cables.
  - Use separate CAN bus cable of 120 Ohm character impedance for MWG (e.g. UNITRONIC BUS-FD P CAN UL/CSA - 2 x 2 x 0.5 mm<sup>2</sup>, manufacturer: Lapp).
  - Data cable connection: XM2-XA2 = CAN L, XM3-XA3 = CAN H.
  - Voltage supply MWG: XM6-XA6 = GND, XM7-XA7 = + 24 V DC (refer to wiring diagram).
- For the electrical connection at wall bracket [3], the terminals are made as crimp connections.
  - Use a suitable four indent crimp tool for crimping.
  - Cross sections for flexible wires:
    - Control cables: max. 0.75 to 1.5 mm<sup>2</sup>
    - Mains connection: max. 2.5 to 4 mm<sup>2</sup>

- When using connecting cables, e.g. of the heater or switch, requiring direct wiring from the actuator to the XK customer plug (XA-XM-XK, refer to wiring diagram), these connecting cables must be subject to an insulation test in compliance with EN 50178. Connecting cables of position transmitters (EWG, RWG, IWG, potentiometer) do not belong to this group. They may **not** be subjected to an insulation test.

### 6.3.2. Parking frame

Figure 33: Parking frame, example with AUMA plug/socket connector and cover



**Application** Parking frame for safe storage of a disconnected plug or cover.  
For protection against touching the bare contacts and against environmental influences.

### 6.3.3. DS intermediate frame for double sealing

Figure 34: Electrical connection with DS intermediate frame

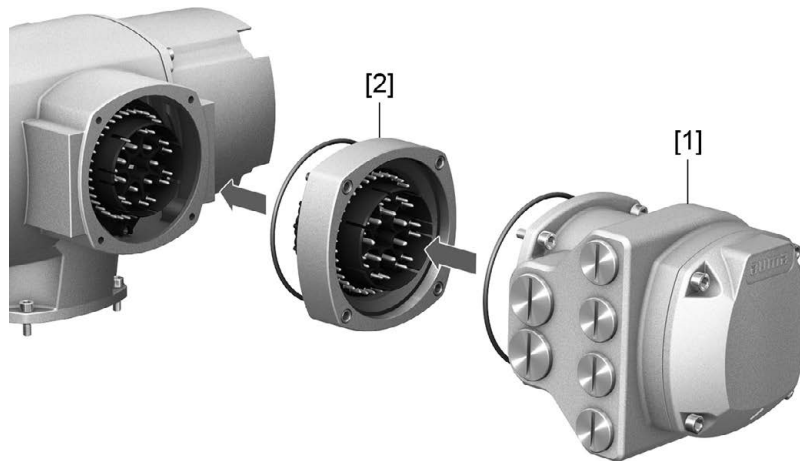

- [1] Electrical connection
- [2] DS intermediate frame

**Application** When removing the electrical connection or due to leaky cable glands, there is a potential risk of ingress of dust and water into the housing. This is prevented effectively by inserting the double sealed intermediate frame [2] between the plug/socket connector [1] and the housing of the device. The enclosure protection of the device (IP68) will not be affected, even if the electrical connection [1] is removed.

**6.3.4. External earth connection**

Figure 35: Earth connection for multi-turn actuator



**Application** External earth connection (U-bracket) for connection to equipotential compensation.

Table 22:

<b>Terminal cross sections and earth connection tightening torques</b>		
Conductor type	Terminal cross sections	Tightening torques
Solid wire and stranded	2.5 mm <sup>2</sup> to 6 mm <sup>2</sup>	3 – 4 Nm
Fine stranded	1.5 mm <sup>2</sup> to 4 mm <sup>2</sup>	3 – 4 Nm

For fine stranded (flexible) wires, connection is made via cable lugs/ring terminals. When connecting two individual wires with a U-bracket, cross sections have to be identical.

## 7. Operation

### 7.1. Manual operation

For purposes of setting and commissioning, in case of motor or power failure, the actuator may be operated manually. Manual operation is engaged by an internal change-over mechanism.

Manual operation is automatically disengaged when motor is started again. The handwheel does not rotate during motor operation.

#### 7.1.1. Manual valve operation



**Damage at the manual change-over mechanism/motor coupling due to faulty operation!**

- Engage manual operation only during motor standstill.
- Do NOT use extensions as lever for operation.

#### Procedure

1. Press push button.
2. Turn handwheel in desired direction.

Figure 36:

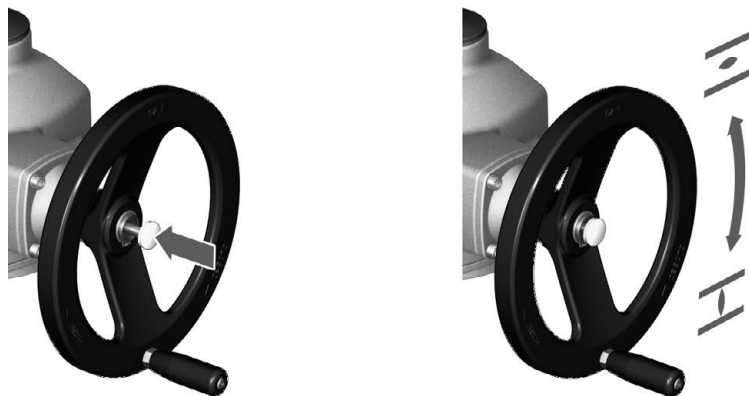

➔ The closing direction is marked on the handwheel.

Table 23: Handwheel marking (examples)

→ For valve closing, turn handwheel in direction of the arrowhead.	
<p>clockwise closing</p>	<p>counterclockwise closing</p>
Drive shaft (valve) turns <b>clockwise</b> in direction CLOSE.	Drive shaft (valve) turns <b>counterclockwise</b> in direction CLOSE.

#### Overload protection for manual operation

To protect the valve, an overload protection is available as option for manual operation. If the torque applied at the handwheel exceeds a certain value (refer to order-related technical data sheet), the shear pins will rupture and thus protect the valve from damage. The handwheel can no longer transmit the torque (= handwheel is spinning). Motor operation is still possible. In case of shear pin rupture due to overload, imperatively replace the safety hub.

Figure 37: Handwheel without/with overload protection



- [1] Handwheel without overload protection (standard)
- [2] Handwheel with overload protection/safety hub (option)

**7.2. Motor operation**

**NOTICE**

**Valve damage due to incorrect basic setting!**

→ Prior to electric actuator operation, perform the basic settings for “type of seating” and “torque switching”.

**7.2.1. Operating the actuator from local controls**

Local actuator operation is performed using the local controls push buttons of actuator controls.

Figure 38: Local controls



- [1] Push button for operation command in direction OPEN
- [2] Push button STOP
- [3] Push button for operation command in direction CLOSE
- [4] Push button RESET
- [5] Selector switch





**Hot surfaces, e.g. possibly caused by high ambient temperatures or strong direct sunlight!**

*Risk of burns*

→ Verify surface temperature and wear protective gloves.

→ Set selector switch [5] to position **Local control** (LOCAL).

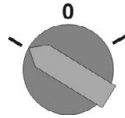

➔ The actuator can now be operated using the push buttons [1 – 3]:

- Run actuator in direction OPEN: Press push button [1]
- Stop actuator: Press push button STOP [2].
- Run actuator in direction CLOSE: Press push button [3]

**Information**

The OPEN and CLOSE operation commands can be given either in push-to-run or in self-retaining operation mode. In self-retaining mode, the actuator runs to the defined end position after pressing the button, unless another command has been received beforehand. For further information, please refer to the Manual (Operation and setting).

**7.2.2. Actuator operation from remote**



**Risk of immediate actuator operation when switching on!**

*Risk of personal injuries or damage to the valve*

→ If the actuator starts unexpectedly: Immediately turn selector switch to **0** (OFF).

→ Check input signals and functions.

→ Set selector switch to position **Remote control** (REMOTE).

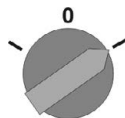

➔ Now, the actuator can be remote-controlled via fieldbus.

**Information**

For actuators equipped with a positioner, it is possible to change over between **OPEN - CLOSE control** (Remote OPEN-CLOSE) and **setpoint control** (Remote SET-POINT). For further information, please refer to the Manual (Operation and setting).

**7.3. Menu navigation via push buttons (for settings and indications)**

Menu navigation for display and setting is made via the push buttons [1 – 4] of the local controls.

Set the selector switch [5] to position **0** (OFF) when navigating through the menu.

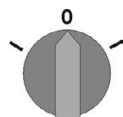

The bottom row of the display [6] serves as navigation support and explains which push buttons [1 – 4] are used for menu navigation.

Figure 39:

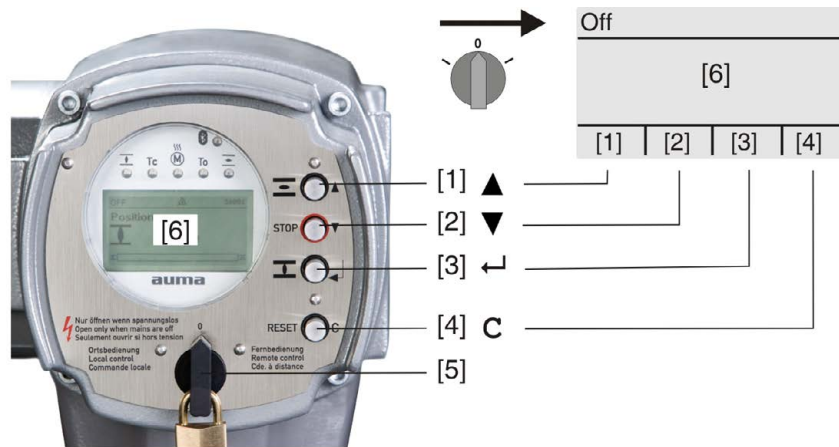

- [1–4] Push buttons or navigation support
- [5] Selector switch
- [6] Display

Table 24: Important push button functions for menu navigation

Push buttons	Navigation support on display	Functions
[1] ▲	Up ▲	Change screen/selection Change values Enter figures from 0 to 9
[2] ▼	Down ▼	Change screen/selection Change values Enter figures from 0 to 9
[3] ↵	Ok	Confirm selection
	Save	Save
	Edit	Enter <Edit> menu
	Details	Display more details
[4] C	Setup	Enter Main menu
	Esc	Cancel process
		Return to previous display

- Backlight**
- The display is illuminated in white during normal operation. It is illuminated in red in case of a fault.
  - The screen illumination is brighter when operating a push button. If no push button is operated for 60 seconds, the display will become dim again.

### 7.3.1. Menu layout and navigation

**Groups** The indications on the display are divided into 3 groups:

Figure 40: Groups



- [1] Start menu
- [2] Status menu
- [3] Main menu

**ID** Status menu and main menu are marked with an ID.

Figure 41: Marking with ID

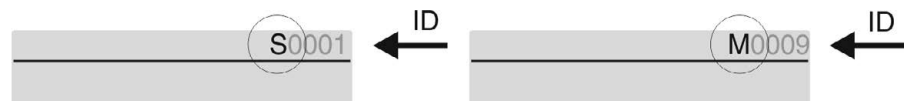

S ID starts with S = status menu  
 M ID starts with M = main menu

**Group selection**

It is possible to select between status menu **S** and main menu **M**:

For this, set selector switch to **0** (OFF), hold down push button **C** for approx. 2 seconds until a screen containing the ID **M...** appears.

Figure 42: Select menu groups

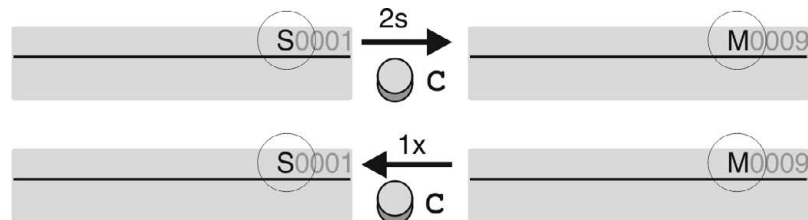

You return to the status menu if:

- the push buttons on the local controls have not been operated within 10 minutes
- or by briefly pressing **C**

**Direct display via ID**

When entering the ID within the main menu, screens can be displayed directly (without clicking through).

Figure 43: Direct display (example)

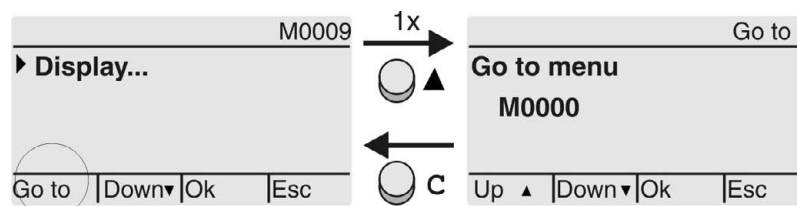

Display indicates in the bottom row: **Go to**

1. Press push button **▲ Go to**.  
 Display indicates: **Go to menu M0000**
2. Use push buttons **▲▼ Up ▲ Down ▼** to select figures 0 to 9.
3. Press push button **◀ Ok** to confirm first digit.
4. Repeat steps 2 and 3 for all further digits.
5. To cancel the process: Press **C Esc**.

**7.4. User level, password**

**User level** The user level defines which menu items or parameters can be displayed or modified by the active user.

There are 6 different user levels. The user level is indicated in the top row:

Figure 44: User level display (example)

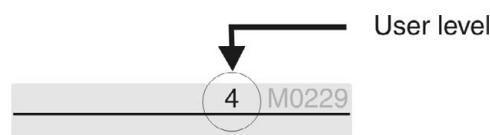

**Password** A password must be entered to allow parameter modification. The display indicates: **Password 0\*\*\***

A specific password is assigned to each user level and permits different actions.

Table 25:

User levels and authorisations	
Designation (user level)	Authorisation/password
Observer (1)	Verify settings No password required
Operator (2)	Change settings Default factory password: 0000
Maintenance (3)	Reserved for future extensions
Specialist (4)	Change device configuration e.g. type of seating, assignment of output contacts Default factory password: 0000
Service (5)	Service staff Change configuration settings
AUMA (6)	AUMA administrator



### Unauthorised access is made easier due to insecure password!

→ We urgently recommend changing the password during initial commissioning.

#### 7.4.1. Password entry

- Select desired menu and hold down push button for approx. 3 seconds.
  - ➔ Display indicates the set user level, e.g. **Observer (1)**
- Select higher user level via **Up** and confirm with **Ok**.
  - ➔ Display indicates: **Password 0\*\*\***
- Use push buttons **Up** **Down** to select figures 0 to 9.
- Confirm first digit of password via push button **Ok**.
- Repeat steps 1 and 2 for all further digits.
  - ➔ Having confirmed the last digit with **Ok**, access to all parameters within one user level is possible if the password entry is correct.

#### 7.4.2. Password change

Only the passwords of same or lower access level may be changed.

Example: If the user is signed in as **Specialist (4)**, he/she can change passwords as for password levels (1) through (4).

- M ▶ **Device configuration M0053**  
**Service functions M0222**  
**Change passwords M0229**

Menu item **Service functions M0222** is only visible, if user level **Specialist (4)** or higher is selected.

#### Select main menu

- Set selector switch to position **0** (OFF).

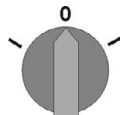

- Press push button **C Setup** and hold it down for approx. 3 seconds.
  - ➔ Display goes to main menu and indicates: ▶ **Display**

- Change passwords**
3. Select parameter **Change passwords** either:
    - click via the menu **M ▷** to parameter, or
    - via direct display: press **▲** and enter ID **M0229**
  - Display indicates: **▶ Change passwords**
  - The user level is indicated in the top row (1 – 6), e.g.:



- For user level 1 (view only), passwords cannot be changed. To change passwords, you must change to a higher user level. For this, enter a password via a parameter.
4. For a user level between 2 and 6: Press push button **↵ Ok**.
  - ➔ The display indicates the highest user level, e.g.: **For user 4**
5. Select user level via push buttons **▲▼ Up ▲ Down ▼** and confirm with **↵ Ok**.
  - ➔ Display indicates: **▶ Change passwords Password 0\*\*\***
6. Enter current password (→ enter password).
  - ➔ Display indicates: **▶ Change passwords Password (new) 0\*\*\***
7. Enter new password (→ enter password).
  - ➔ Display indicates: **▶ Change passwords For user 4 (example)**
8. Select next user level via push buttons **▲▼ Up ▲ Down ▼** or cancel the process via **Esc**.

### 7.4.3. Timeout for incorrect password entry

A timeout for incorrect password entry is provided with actuator controls. This prevents unauthorised access by systematic trials. The timeout is active for incorrect entries via the local controls as well as incorrect entries via our software tools (AUMA CDT, AUMA Assistant App). After five subsequent incorrect trials, further entry is inhibited for one minute. Each further incorrect entry doubles the timeout period. An active timeout is displayed on the screen. An individual timeout is available for each user level. This means that you may still log on with user level 3 if user level 4 is inhibited.

The incorrect entry counter can be reset in two ways:

1. Correct password entry with successful access authorisation.
2. 8 hours after the last incorrect entry.

### 7.5. Language in the display

The display language can be selected.

#### 7.5.1. Language change

**M ▷** **Display M0009**  
**Language M0049**

- Select main menu**
1. Set selector switch to position **0** (OFF).

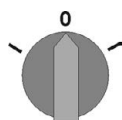

**Change language**

2. Press push button **C Setup** and hold it down for approx. 3 seconds.
  - ➔ Display goes to main menu and indicates: **▶ Display**
3. Press **↵ Ok**.
  - ➔ Display indicates: **▶ Language**
4. Press **↵ Ok**.
  - ➔ Display indicates the selected language, e.g.: **▶ Deutsch**

**Language selection**

5. The bottom row of the display indicates:
  - **Save** → continue with step 10
  - **Edit** → continue with step 6
6. Press **← Edit**.
  - ➔ Display indicates: **▶ Observer (1)**
7. Select user level via **▲▼ Up ▲ Down ▼** resulting in the following significations:
  - black triangle: **▶** = current setting
  - white triangle: **▷** = selection (not saved yet)
8. Press **← Ok**.
  - ➔ Display indicates: **Password 0\*\*\***
9. Enter password (→ enter password).
  - ➔ Display indicates: **▶ Language** and **Save** (bottom row)
10. Select new language via **▲▼ Up ▲ Down ▼** resulting in the following significations:
  - black triangle: **▶** = current setting
  - white triangle: **▷** = selection (not saved yet)
11. Confirm selection via **← Save**.
  - ➔ The display changes to the new language. The new language selection is saved.

## 8. Indications

### 8.1. Indications during commissioning

**LED test** When switching on the power supply, all LEDs on the local controls illuminate for approx. 1 second. This optical feedback indicates that the voltage supply is connected to the controls and all LEDs are operable.

Figure 45: LED test

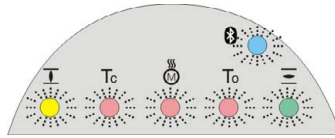

**Language selection** During the self-test, the language selection can be activated so that the selected language is immediately indicated in the display. For this, set selector switch to position **0** (OFF).

#### Activate language selection:

1. Display indicates in the bottom line: **Language selection menu? 'Reset'**
2. Hold down push button **RESET** until display of the following text in the bottom line: **Language menu loading, please wait.**

Figure 46: Self-test

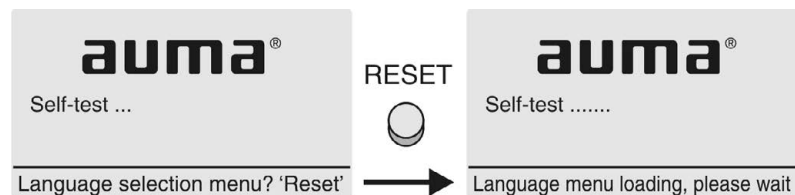

The language selection menu follows the startup menu.

**Startup menu** The current firmware version is displayed during the startup procedure:

Figure 47: Startup menu with firmware version: 05.00.00–xxxx

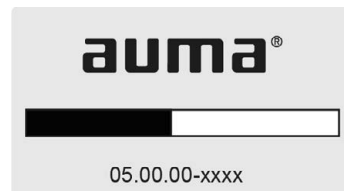

If the language selection feature has been activated during the self-test, the menu for selecting the display language will now be indicated. For further information on language setting, please refer to chapter <Language in the display>.

Figure 48: Language selection

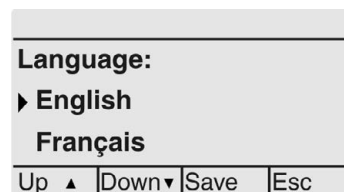

If no entry is made over a longer period of time (approx. 1 minute), the display automatically returns to the first status indication.

### 8.2. Indications in the display



#### Menus and functions depend on the actuator controls firmware version!

→ Should menus or functions be unavailable, please contact the AUMA Service.

**Status bar** The status bar (first row in the display) indicates the operation mode [1], the presence of an error [2] and the ID number [3] of the current display indication.

Figure 49: Information in the status bar (top)

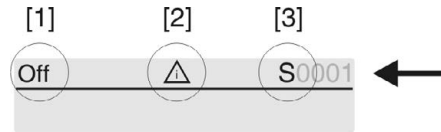

- [1] Operation mode
- [2] Error symbol (only for faults and warnings)
- [3] ID number: S = Status page

**Navigation support** If further details or information are available with reference to the display, the following indications **Details** or **More** appear in the navigation support (bottom display row). Then, further information can be displayed via the ← push button.

Figure 50: Navigation support (bottom)

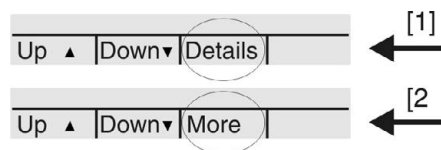

- [1] shows list with detailed indications
- [2] shows further available information

The navigation support (bottom row) is faded out after approx. 3 seconds. Press any push button (selector switch in position 0 (OFF)) to fade in the navigation support.

### 8.2.1. Feedback signals from actuator and valve

Display indications depend on the actuator version.

#### Valve position (S0001)

- S0001 on the display indicates the valve position in % of the travel.
- The bar graph display appears after approx. 3 seconds.
- When issuing an operation command, an arrow indicates the direction (OPEN/CLOSE).

Figure 51: Valve position and direction of operation

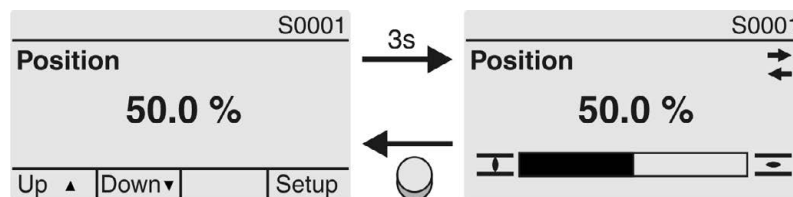

Reaching the preset end positions is additionally indicated via (CLOSED) and (OPEN) symbols.

Figure 52: End position CLOSED/OPEN reached

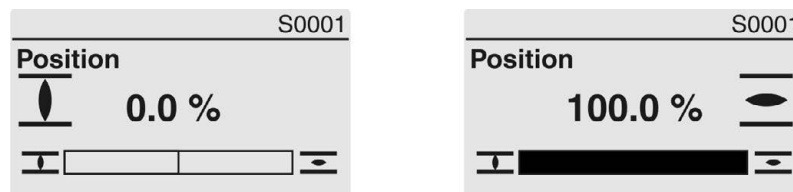

- 0% Actuator is in end position CLOSED
- 100% Actuator is in end position OPEN

#### Torque (S0002)

- S0002 on the display indicates the torque applied at the actuator output.



- The bar graph display appears after approx. 3 seconds.

Figure 53: Torque

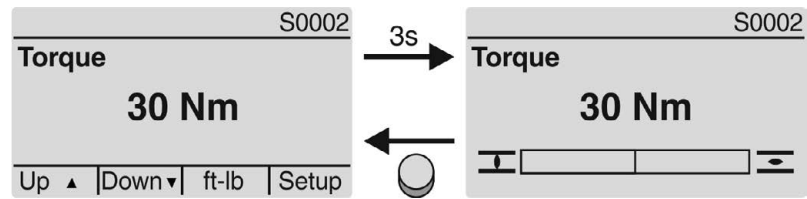

**Select unit**

The push button allows to select the unit displayed (percent %, Newton metre Nm or "foot-pound" ft-lb)

Figure 54: Units of torque

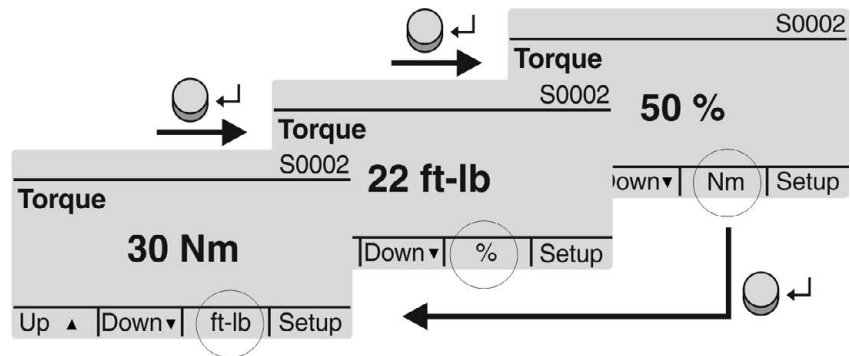

**Display in percent**

100 % indication equals the max. torque indicated on the name plate of the actuator.

Example: Torque range on name plate = 20 – 60 Nm.

- 100 % corresponds to 60 Nm of nominal torque.
- 50 % corresponds to 30 Nm of nominal torque.

**Operation commands (S0003)**

The display S0003 indicates:

- active operation commands, like e.g.: Operation in direction CLOSE or in direction OPEN
- the actual value E2 as bar graph indication and as value between 0 and 100 %.
- for setpoint control (positioner): setpoint E1
- for stepping mode or for intermediate positions with operation profile: pivot points and operation behaviour of pivot points

The navigation support (bottom row) is faded out after approx. 3 seconds and the axis/axes for pivot point display are shown.

**OPEN - CLOSE control**

Active operation commands (OPEN, CLOSE, ...) are shown above the bar graph display. The figure below shows the operation command in direction CLOSE.

Figure 55: Display for OPEN - CLOSE control

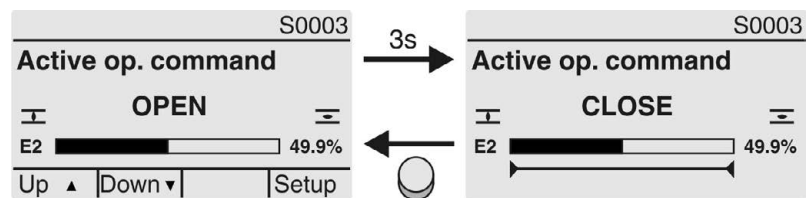

E2 Actual position value

**Setpoint control**

If the positioner is enabled and activated, the bar graph indication for E1 (position setpoint) is displayed.

The direction of the operation command is displayed by an arrow above the bar graph indication. The figure below shows the operation command in direction CLOSE.

Figure 56: Indication for setpoint control (positioner)

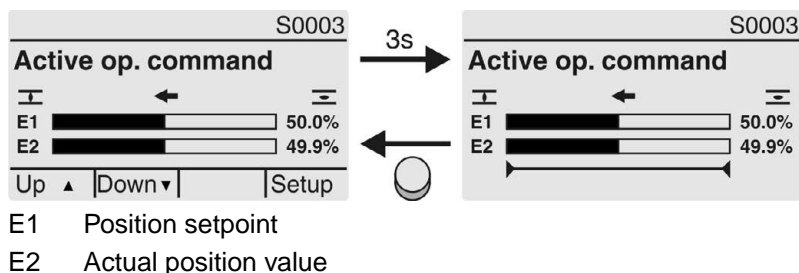

**Pivot point axis**

The pivot points and their operation behaviour (operation profile) are shown on the pivot point axis by means of symbols.

The symbols are only displayed if at least one of the following functions is activated:

Operation profile M0294

Timer CLOSE M0156

Timer OPEN M0206

Figure 57: Examples: on the left pivot points (intermediate positions); on the right stepping mode



Table 26: Symbols along the pivot point axis

Symbol	Pivot point (intermediate position) with operation profile	Stepping mode
	Pivot point without reaction	End of stepping mode
◀	Stop during operation in direction CLOSE	Start of stepping mode in direction CLOSE
▶	Stop during operation in direction OPEN	Start of stepping mode in direction OPEN
◆	Stop during operation in directions OPEN and CLOSE	–
◁	Pause for operation in direction CLOSE	–
▷	Pause for operation in direction OPEN	–
◇	Pause for operation in directions OPEN and CLOSE	–

**8.2.2. Status indications according to AUMA classification**

These indications are available if the parameter **Diagnostic classific. M0539** is set to **AUMA**.

**Warnings (S0005)**

If a warning has occurred, the display shows **S0005**:

- the number of warnings occurred
- a blinking question mark after approx. 3 seconds

Figure 58: Warnings

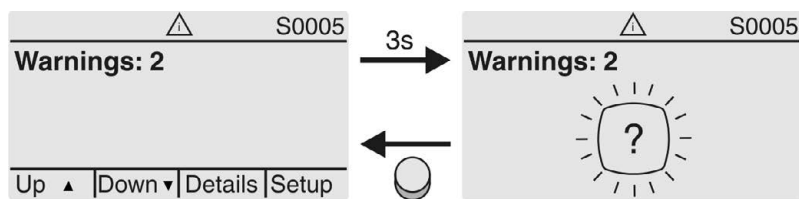

For further information, please also refer to <Corrective action>.

**Not ready REMOTE (S0006)**

The S0006 display shows indications of the Not ready REMOTE group.

If such an indication has occurred, the display shows S0006:

- the number of indications occurred
- a blinking crossbar after approx. 3 seconds

Figure 59: Not ready REMOTE indications

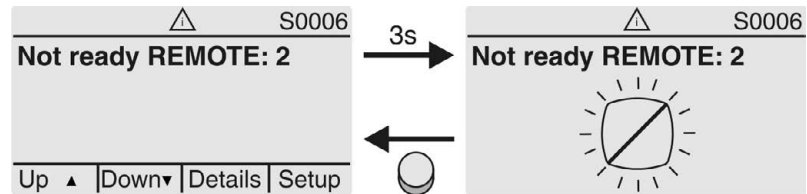

For further information, please also refer to <Corrective action>.

**Fault (S0007)**

If a fault has occurred, the display shows S0007:

- the number of faults occurred
- a blinking exclamation mark after approx. 3 seconds

Figure 60: Fault

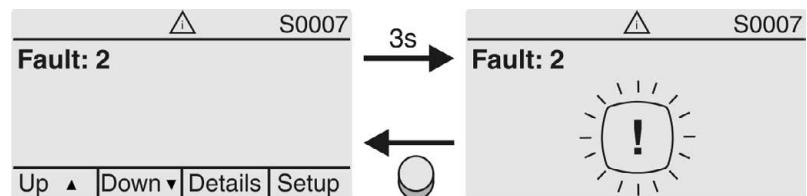

For further information, please also refer to <Corrective action>.

**8.2.3. Status indications according to NAMUR recommendation**

These indications are available, if the parameter **Diagnostic classific. M0539** is set to **NAMUR**.

**Out of Specification (S0008)**

The S0008 indication shows out of specification indications according to NAMUR recommendation NE 107.

If such an indication has occurred, the display shows S0008:

- the number of indications occurred
- a blinking triangle with question mark after approx. 3 seconds

Figure 61: Out of specification

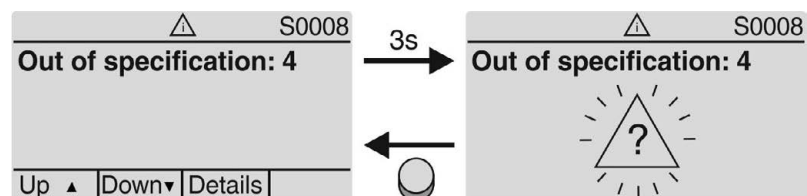

For further information, please also refer to <Corrective action>.

**Function check (S0009)**

The S0009 indication shows function check indications according to NAMUR recommendation NE 107.

If an indication has occurred via the function check, the display shows S0009:

- the number of indications occurred
- a blinking triangle with a spanner after approx. 3 seconds

Figure 62: Function check

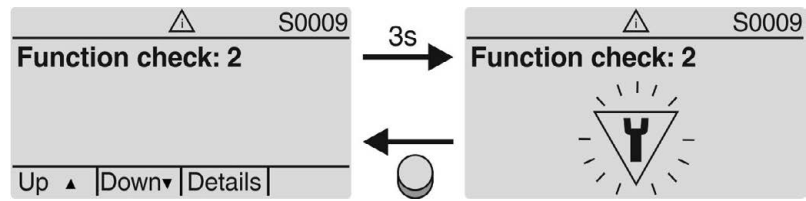

For further information, please also refer to <Corrective action>.

**Maintenance required (S0010)**

The S0010 indication shows maintenance indications according to NAMUR recommendation NE 107.

If such an indication has occurred, the display shows S0010:

- the number of indications occurred
- a blinking square with an oilcan after approx. 3 seconds

Figure 63: Maintenance required

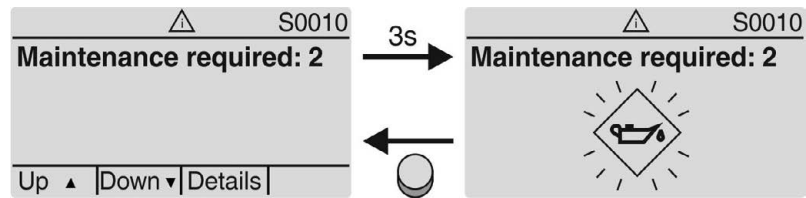

For further information, please also refer to <Corrective action>.

**Failure (S0011)**

The S0011 indication shows the causes of the failure indication according to NAMUR recommendation NE 107.

If such an indication has occurred, the display shows S0011:

- the number of indications occurred
- a blinking circle with a cross after approx. 3 seconds

Figure 64: Failure

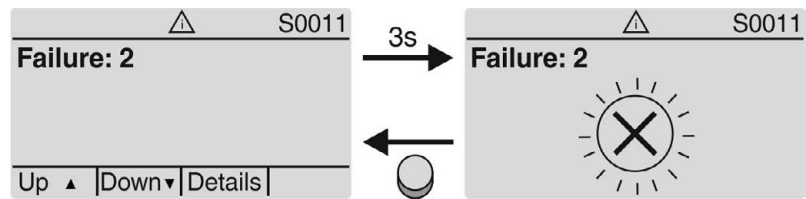

For further information, please also refer to <Corrective action>.

**8.3. Indication lights of local controls**

Figure 65: Arrangement and signification of indication lights

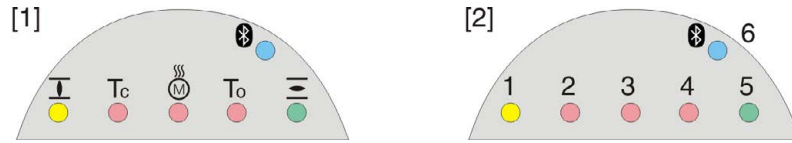

- [1] Marking with symbols (standard)
- [2] Marking with figures 1 – 6 (option)
- 1 End position CLOSED reached (blinking: operation in direction CLOSE)
- 2 Tc Torque fault CLOSE
- 3 Motor protection tripped
- 4 To Torque fault OPEN
- 5 End position OPEN reached (blinking: operation in direction OPEN)
- 6 Bluetooth connection active

**Modify indication light assignment (indications)**

Different indications can be assigned to LEDs 1 – 5.

- M ▷ **Device configuration M0053**
- Local controls M0159**
- Indication light 1 (left) M0093**
- Indication light 2 M0094**
- Indication light 3 M0095**
- Indication light 4 M0096**
- Indicat. light 5 (right) M0097**
- Signal interm. pos. M0167**

**Default values (Europe):**

- Indication light 1 (left) = End p. CLOSED, blink**
- Indication light 2 = Torque fault CLOSE**
- Indication light 3 = Thermal fault**
- Indication light 4 = Torque fault OPEN**
- Indicat. light 5 (right) = End p. OPEN, blink**
- Signal interm. pos. = OPEN/CLOSED = Off**

**Further setting values:**

Refer to Manual (Operation and setting).

## 8.4. Optional indications

### 8.4.1. Mechanical position indication (self-adjusting)

Figure 66: Mechanical position indicator



- [1] End position OPEN reached
- [2] End position CLOSED reached

#### Characteristics

- Independent of power supply
- Used as running indication: Indicator disc (with arrow  $\Rightarrow$ ) rotates during actuator operation and continuously indicates the valve position (For "clockwise closing version", the arrow rotates in clockwise direction for operation in direction CLOSE)
- Indicates that end positions (OPEN/CLOSED) have been reached  
Arrow  $\Rightarrow$  points to symbol  $\ominus$  (OPEN) or  $\perp$  (CLOSED)
- Self-adjusting during commissioning (cover must not be opened)

### 8.4.2. Mechanical position indication via indicator mark (not self-adjusting)

Figure 67: Mechanical position indicator



- [1] End position OPEN reached
- [2] End position CLOSED reached
- [3] Indicator mark at cover

#### Characteristics

- Independent of power supply
- Used as running indication: Indicator disc rotates during actuator operation and continuously indicates the valve position (For "clockwise closing" version, the symbols  $\ominus/\perp$  rotate in counterclockwise direction for operations in direction CLOSE)
- Indicates that end positions (OPEN/CLOSED) have been reached (Symbols  $\ominus$  (OPEN)/  $\perp$  (CLOSED) point to the indicator mark  $\blacktriangle$  at cover)

## 9. Signals (output signals)

### 9.1. Signals via fieldbus

Feedback signals via fieldbus can be configured. Configuration is possible for both data structure and data contents.

Configuration is defined via the GSD file only.

**Information** If required, download the GSD file (General Station Description) from the Internet: [www.auma.com](http://www.auma.com)

For information on the feedback signals via fieldbus and the configuration of the parameters via fieldbus interface, refer to Manual (Device integration fieldbus) Profibus DP.

### 9.2. Status signals via output contacts (digital outputs)

**Conditions** Output contacts are only available if a parallel interface is provided in addition to the fieldbus interface.

**Characteristics** Output contacts are used to send status signals (e.g. reaching the end positions, selector switch position, faults...) as binary signals to the control room.

Status signals only have two states: active or inactive. Active means that the conditions for the signal are fulfilled.

#### 9.2.1. Assignment of outputs

The output contacts (outputs DOUT 1 – 6) can be assigned to various signals.

Required user level: **Specialist (4)** or higher.

M ▷ **Device configuration M0053**  
    **I/O interface M0139**  
        **Digital outputs M0110**  
            **Signal DOUT 1 M0109**

**Default values:**

**Signal DOUT 1 = Fault**  
**Signal DOUT 2 = End position CLOSED**  
**Signal DOUT 3 = End position OPEN**  
**Signal DOUT 4 = Selector sw. REMOTE**  
**Signal DOUT 5 = Torque fault CLOSE**  
**Signal DOUT 6 = Torque fault OPEN**

#### 9.2.2. Coding the outputs

The output signals **Coding DOUT 1 – Coding DOUT 6** can be set either to high active or low active.

- High active = output contact closed = signal active
- Low active = output contact open = signal active

Signal active means that the conditions for the signal are fulfilled.

Required user level: **Specialist (4)** or higher.

M ▷ **Device configuration M0053**  
    **I/O interface M0139**  
        **Digital outputs M0110**  
            **Coding DOUT 1 M0102**

**Default values:**

**Coding DOUT 1 = Low active**  
**Coding DOUT 2–Coding DOUT 6 = High active**

### 9.3. Analogue signals (analogue outputs)

<b>Requirements</b>	Analogue signals are only available if additional input signals are provided.
<b>Valve position</b>	Signal: E2 = 0/4 – 20 mA (galvanically isolated) Designation in the wiring diagram: AOUT1 (position)
<b>Torque feedback</b>	Signal: E6 = 0/4 – 20 mA (galvanically isolated) Designation in the wiring diagram: AOUT2 (torque) For further information on this topic, please refer to Manual (Operation and setting).



## 10. Commissioning (basic settings)

1. Set selector switch to position **0** (OFF).

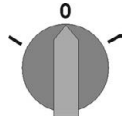

**Information:** The selector switch is not a mains switch. When positioned to **0** (OFF), the actuator cannot be operated. The controls' power supply is maintained.

2. Switch on the power supply.

**Information:** Observe heat-up time for ambient temperatures below  $-30\text{ }^{\circ}\text{C}$ .

3. Perform basic settings.

### 10.1. Type of seating: set

#### NOTICE

#### Valve damage due to incorrect setting!

- The type of seating setting (limit or torque seating) must match the selection for the valve.
- Only change the setting with prior consent of the valve manufacturer.

M ▶ Customer settings M0041  
 Type of seating M0012  
 End position CLOSED M0086  
 End position OPEN M0087

**Default value:** Limit

#### Setting values:

**Limit** Seating in end positions via limit switching.

**Torque** Seating in end positions via torque switching.

- Select main menu**
1. Set selector switch to position **0** (OFF).

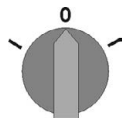

2. Press push button **C Setup** and hold it down for approx. 3 seconds.

➔ Display goes to main menu and indicates: ▶ **Display**

- Select parameter**
3. Select parameter either:

→ click via the menu M ▶ to parameter, or

→ via direct display: Press ▲ and enter ID M0086 or M0087

➔ Display indicates: End position **CLOSED**

- CLOSE or OPEN**
4. Use ▲ ▼ Up ▲ Down ▼ to select:

→ ▶ End position **CLOSED**

→ ▶ End position **OPEN**

➔ The black triangle ▶ indicates the current selection.

5. Press ↵ **Ok**.

➔ Display indicates the current setting: **Limit** or **Torque**

➔ The bottom row of the display indicates either:

- **Edit** → continue with step 6

- **Save** → continue with step 10

- User login**
6. Press **← Edit**.
  - ➔ Display indicates: **▶ Specialist (4)**
  7. Use **▲▼ Up ▲ Down ▼** to select user:  
**Information:** Required user level: **Specialist (4)** or higher
  - ➔ The symbols have the following meaning:
    - black triangle: ▶ = current setting
    - white triangle: ▷ = selection (not saved yet)
  8. Press **← Ok**.
  - ➔ Display indicates: **Password 0\*\*\***
  9. Enter password (→ enter password).
  - ➔ The screen indicates the pre-set type of seating (**▶ Limit** or **▶ Torque**) by means of a black triangle ▶.
- Change settings**
10. Use **▲▼ Up ▲ Down ▼** to select new setting.
  - ➔ The symbols have the following meaning:
    - black triangle: ▶ = current setting
    - white triangle: ▷ = selection (not saved yet)
  11. Confirm selection via **← Save**.
  - ➔ The setting for the type of seating is complete.
  12. Back to step 4 (CLOSED or OPEN): Press **← Esc**.

## 10.2. Torque switching: set

Once the set torque is reached, the torque switches will be tripped (overload protection of the valve).

**Information** The torque switches may also trip during manual operation.

### NOTICE

#### Valve damage due to excessive tripping torque limit setting!

- The tripping torque must suit the valve.
- Only change the setting with the consent of the valve manufacturer.

**M ▶** Customer settings **M0041**  
Torque switching **M0013**  
Trip torque CLOSE **M0088**  
Trip torque OPEN **M0089**

**Default value:** According to order data

**Setting range:** Torque range according to actuator name plate

- Select main menu**
1. Set selector switch to position **0** (OFF).

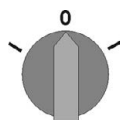

2. Press push button **C Setup** and hold it down for approx. 3 seconds.
- ➔ Display goes to main menu and indicates: **▶ Display**

**Select parameter**

3. Select parameter either:
  - click via the menu **M ▶** to parameter, or
  - via direct display: press **▲** and enter ID **M0088**.
- ➔ Display indicates: **Trip torque CLOSE**

- CLOSE or OPEN**
4. Use ▲▼ Up ▲ Down ▼ to select:
    - ▶ Trip torque CLOSE
    - ▶ Trip torque OPEN
    - ➔ The black triangle ▶ indicates the current selection.
  5. ⏪ Press **OK**.
    - ➔ Display shows the set value.
    - ➔ The bottom row indicates: **Edit Esc**
  6. ⏪ Press **Edit**.
    - ➔ Display indicates:
      - **Specialist (4)** → continue with step 7
      - in bottom row **Up ▲ Down ▼ Esc** → continue with step 11
- User login**
7. Use ▲▼ Up ▲ Down ▼ to select user:
    - Information:** Required user level: **Specialist (4)** or higher.
    - ➔ The symbols have the following meanings:
      - black triangle: ▶ = current setting
      - white triangle: ▷ = selection (not saved yet)
  8. ⏪ Press **OK**.
    - ➔ Display indicates: **Password 0\*\*\***
  9. Enter password (→ enter password).
    - ➔ Display shows the set value.
    - ➔ The bottom row indicates: **Edit Esc**
  10. ⏪ Press **Edit**.

- Change value**
11. Enter new value for tripping torque via ▲▼ Up ▲ Down ▼.
    - Information:** The adjustable torque range is shown in round brackets.
  12. Save new value via ⏪ **Save**.
    - ➔ The tripping torque is set.
  13. Back to step 4 (CLOSED or OPEN): Press ⏪ **Esc**.

- Information**
- The following fault signals are issued if the torque setting performed has been reached **in mid-travel**:
- In the display of the local controls: Status indication **S0007 Fault = Torque fault OPEN** or **Torque fault CLOSE**

The fault has to be acknowledged before the operation can be resumed. The acknowledgement is made:

1. either by an operation command in the opposite direction.
  - For **Torque fault OPEN**: Operation command in direction **CLOSE**
  - For **Torque fault CLOSE**: Operation command in direction **OPEN**
2. or, in case the torque applied is lower than the preset tripping torque:
  - in selector switch position **Local control (LOCAL)** via push button **RESET**.
  - in selector switch position **Remote control (REMOTE)**:
    - via the fieldbus, command reset., if the fieldbus is the active command source.
    - via a digital input (I/O interface) with **RESET** command if a digital input is configured for signal **RESET** and the I/O interface is the active command source.

**10.3. Limit switching: set****NOTICE****Valve damage at valve/gearbox due to incorrect setting!**

- When setting with motor operation: Stop actuator **prior** to reaching end of travel (press STOP push button).
- For limit seating, provide for sufficient backlash between end position and mechanical end stop due to potential overrun.

- M ▶** Customer settings M0041  
 Limit switching M0010  
 Set end pos. CLOSED? M0084  
 Set end pos. OPEN? M0085

- Select main menu** 1. Set selector switch to position **0** (OFF).

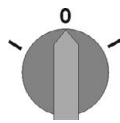

2. Press push button **C** and hold it down for approx. 3 seconds.

➔ Display goes to main menu and indicates: ▶ **Display**

- Select parameter** 3. Select parameter either:

- click via the menu **M ▶** to parameter, or
- via direct display: press **▲** and enter ID **M0084**.

➔ Display indicates: **Set end pos. CLOSED?**

- CLOSED or OPEN** 4. Select via **▲ ▼ Up ▲ Down ▼**:

- ▶ **Set end pos. CLOSED? M0084**
- ▶ **Set end pos. OPEN? M0085**

➔ The black triangle ▶ indicates the current selection.

5. Press **↵ Ok**.

➔ The display indicates either:

- **Set end pos. CLOSED? CMD0009** → continue with step 9
- **Set end pos. OPEN? CMD0010** → continue with step 12
- **Specialist (4)** → continue with step 6

- User login** 6. Use **▲ ▼ Up ▲ Down ▼** to select user:

**Information:** Required user level: **Specialist (4)** or higher

➔ The symbols have the following meaning:

- black triangle: ▶ = current setting
- white triangle: ▷ = selection (not saved yet)

7. Press **Ok** to confirm selected user.

➔ Display indicates: **Password 0\*\*\***

8. Enter password (→ enter password).

➔ The display indicates either:

- **Set end pos. CLOSED? CMD0009** → continue with step 9
- **Set end pos. OPEN? CMD0010** → continue with step 12

**Set end position  
 CLOSED** **CMD0009**

9. Set end position CLOSED again :
  - 9.1 For large strokes: Set selector switch in position **Local control** (LOCAL) and operate actuator in motor operation via push button  (CLOSE) in direction of the end position.  
**Information:** Stop actuator **before** reaching end of travel (press **STOP** push button to avoid damage).
  - 9.2 Engage manual operation.
  - 9.3 Turn handwheel until valve is closed.
  - 9.4 Turn handwheel by approximately half a turn (overrun) in the opposite direction of end position.
  - 9.5 Set selector switch to position **0** (OFF).  
 ➔ Display indicates: **Set end pos.CLOSED? Yes No**

**Confirm new end position**

10. Press  **Yes** to confirm new end position.  
 ➔ Display indicates: **End pos. CLOSED set!**  
 ➔ The left LED is illuminated (standard version) and thus indicates that the end position CLOSED setting is complete.

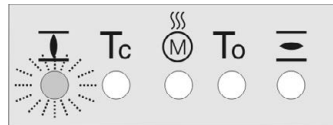

11. Make selection:
  - **Edit** → back to step 9: Set end position CLOSED "once again"
  - **Esc** → back to step 4; either set end position OPEN or exit the menu.

**Set end position OPEN** **CMD0010**

12. Re-set end position OPEN:
  - 12.1 For large strokes: Set selector switch in position **Local control** (LOCAL) and operate actuator in motor operation via push button  (OPEN) in direction of the end position.  
**Information:** Stop actuator **before** reaching end of travel (press **STOP** push button to avoid damage).
  - 12.2 Engage manual operation.
  - 12.3 Turn handwheel until valve is open.
  - 12.4 Turn handwheel by approximately half a turn (overrun) in the opposite direction of end position.
  - 12.5 Set selector switch to position **0** (OFF).  
 ➔ Display indicates: **Set end pos. OPEN? Yes No**

**Confirm new end position**

13. Press  **Yes** to confirm new end position.  
 ➔ Display indicates: **End pos. OPEN set!**  
 ➔ The right LED is illuminated (standard version) and thus indicates that the end position OPEN setting is complete.

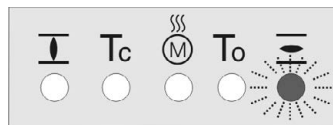

14. Make selection:
  - **Edit** → back to step 12: Set end position OPEN "once again"
  - **Esc** → back to step 4; either set end position CLOSED or exit the menu.

**Information** If an end position cannot be set: Check the type of control unit in actuator.

**10.4. Fieldbus address (slave address): set**

M ▶ Customer settings M0041  
 Profibus DP M0016  
 DP1 slave address M0098  
 DP2 slave address M0295

**Default value:** 126

**Setting range:** 0 – 126

**Information** Parameter **DP2 slave address** is only available if redundancy (option) is available.

**Select main menu**

1. Set selector switch to position **0** (OFF).

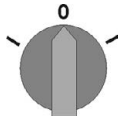

2. Press push button **C Setup** and hold it down for approx. 3 seconds.

➔ Display goes to main menu and indicates: ▶ **Display**

**Set fieldbus address**

3. Select parameter either:

→ **M ▶** (by clicking through the menu)

→ or press **▲** and enter IDs **M0098** or **M0295** (direct selection)

➔ Display indicates: **DP1 slave address**

4. Select via **▲▼ Up ▲ Down ▼**:

→ ▶ **DP1 slave address**

→ ▶ **DP2 slave address**

➔ The black triangle ▶ indicates the current selection.

5. Press **↵ Ok**.

➔ Display shows the set address.

6. The bottom row of the display indicates:

→ **Edit** → continue with step 7

→ **Up ▲ Down ▼** → continue with step 11

7. Press **↵ Edit**.

➔ Display indicates: **Observer (1)**

8. Select access level via **▲▼ Up ▲ Down ▼**, resulting in the following significations:

→ black triangle: ▶ = current setting

→ white triangle: ▷ = selection (not saved yet)

**Information:** Required access level: **Specialist (4)** or higher

9. Press **↵ Ok**.

➔ Display indicates: **Password 0\*\*\***

10. Enter password (→ enter password).

➔ Display shows the set address.

11. Enter new address via **▲▼ Up ▲ Down ▼**.

**Information:** The address range is displayed in round brackets on the screen.

12. Confirm selection via **↵ Save**.

➔ The setting for the Profibus address is complete.

**10.5. Test run**

Only perform test run only once all settings previously described have been performed.

The direction of rotation can be checked at the position indicator if available. (Chapter <Direction of rotation at mechanical position indicator: check>)

The direction of rotation must be checked at the hollow shaft/stem if no mechanical position indicator is available. (Chapter <Direction of rotation at hollow shaft/stem: check>)

**10.5.1. Direction of rotation at mechanical position indicator: check**

**NOTICE**

**Valve damage due to incorrect direction of rotation!**

- If the direction of rotation is wrong, switch off immediately (press STOP).
- Eliminate cause, i.e. correct phase sequence for cable set wall bracket.
- Repeat test run.

**Information**

Switch off before reaching the end position.

1. Move actuator manually to intermediate position or to sufficient distance from end position.
2. Switch on actuator in direction CLOSE and observe the direction of rotation on the mechanical position indication:

→ **For self-adjusting mechanical position indication:**

- The direction of rotation is correct if the actuator operates in direction **CLOSE** and arrow ⇨ turns **clockwise** in direction CLOSE (symbol  $\overline{\downarrow}$ ).
- Figure 68: Direction of rotation ⇨ (for “clockwise closing” version)



→ **For mechanical position indication via indicator mark: (not self-adjusting)**

- The direction of rotation is correct if the actuator operation in direction **CLOSE** and the symbols  $\overline{\downarrow}$  turn **counterclockwise**:

Figure 69: Direction of rotation  $\overline{\downarrow}$  (for “clockwise closing version”)



**10.5.2. Direction of rotation at hollow shaft/stem: check**

Figure 70: Direction of rotation of the hollow shaft/stem for operation in direction CLOSE ("clockwise closing" version)

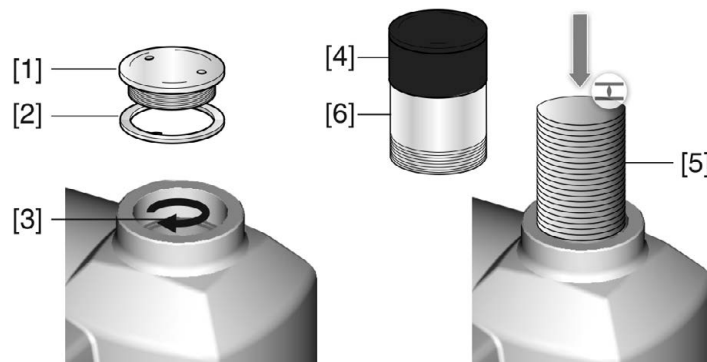

- [1] Threaded plug
- [2] Seal
- [3] Hollow shaft
- [4] Protective cap for stem protection tube
- [5] Stem
- [6] Stem protection tube

**NOTICE****Valve damage due to incorrect direction of rotation!**

- If the direction of rotation is wrong, switch off immediately (press STOP).
- Eliminate cause, i.e. correct phase sequence for cable set wall bracket.
- Repeat test run.

**Check direction of rotation**

1. Move actuator manually to intermediate position or to sufficient distance from end position.
2. Depending on the version: Unscrew threaded plug [1] with seal [2], protective cap [4] or stem protection tube [6].
3. Switch on actuator in direction CLOSE and observe direction of rotation at hollow shaft [3] or stem [5]:
  - ➔ The direction of rotation is correct if the actuator moves in direction **CLOSE** and the hollow shaft in **clockwise** direction, or the stem moves downward.
4. Correctly fit/screw on threaded plug [1] with seal [2], protective cap [4] for stem protection tube [6], fasten thread.

**10.5.3. Limit switching: check**

1. Set selector switch to position **Local control** (LOCAL).

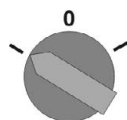



2. Operate actuator using push buttons OPEN, STOP, CLOSE.
  - ➔ The limit switching is set correctly if (default indication):
    - the yellow indication light/LED1 is illuminated in end position CLOSED
    - the green indication light/LED5 is illuminated in end position OPEN
    - the indication lights go out after travelling into opposite direction.
  - ➔ The limit switching is set incorrectly if:
    - the actuator comes to a standstill before reaching the end position
    - one of the red indication lights/LEDs is illuminated (torque fault)
    - the status indication **S0007** in the display signals a fault.
3. If the end position setting is incorrect: Reset limit switching.

## 11. Commissioning (settings/options in the actuator)

For actuators without mechanical position indicator (cover without indicator glass), no settings are required within the actuator when commissioning.

When equipped with the self-adjusting mechanical position indication [A], the position indication automatically adjusts upon the initial operation (e.g. from CLOSED to OPEN). This self-adjustment is generally performed when setting the limit switches (approaching the end positions). Manual setting and consequently opening the switch compartment is not necessary when commissioning.

In case the mechanical position indicator integrated within the actuator is NOT self-adjusting [B], the switch compartment must be opened for mechanical position indication adjustment when commissioning.

Figure 71: Mechanical position indications

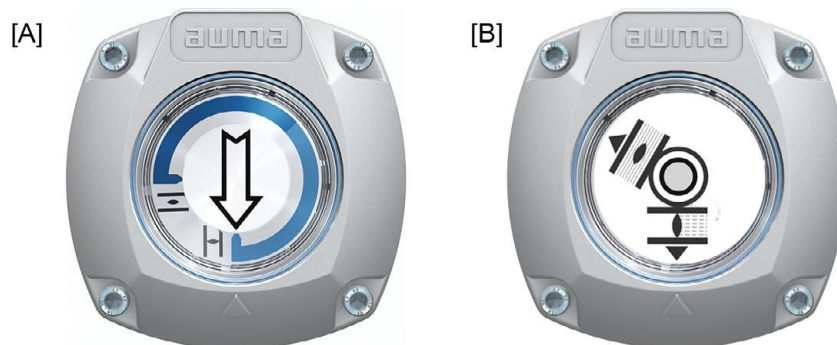

- [A] Mechanical position indicator (self-adjusting)  
[B] Mechanical position indication via indicator mark (not self-adjusting)

### 11.1. Switch compartment: open/close

Figure 72: Open/close switch compartment

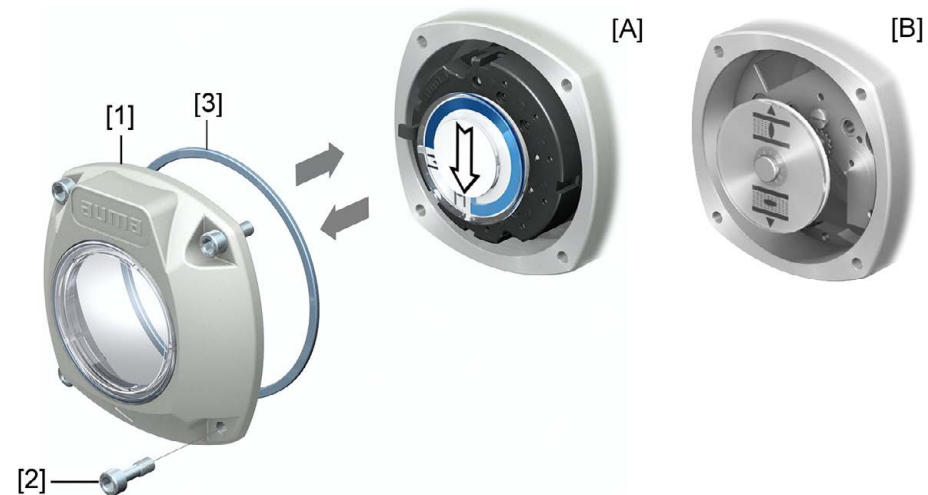

- [A] Mechanical position indication (self-adjusting)  
[B] Mechanical position indication via indicator mark

- Open**
1. Loosen screws [2] and remove cover [1] from the switch compartment.
- Close**
2. Clean sealing faces of housing and cover.
  3. Check whether O-ring [3] is in good condition, replace if damaged.
  4. Apply a thin film of non-acidic grease (e.g. petroleum jelly) to the O-ring and insert it correctly.
  5. Place cover [1] on switch compartment.
  6. Fasten screws [2] evenly crosswise.

## 11.2. Mechanical position indicator (self-adjusting)

Figure 73: Mechanical position indicator (self-adjusting)



The self-adjusting mechanical position indicator shows the valve position by means of an arrow  $\Rightarrow$ . When correctly set, the arrow points to symbol  $\equiv$  (OPEN) or  $\perp$  (CLOSED) in the end positions.

**Information** The position indications is housed in the actuator switch compartment. Opening the switch compartment for manual setting is only necessary if the gear stage setting must be modified or if the factory settings of predefined end position CLOSED (or OPEN) must be adapted when commissioning.

### 11.2.1. Mechanical position indicator: set

1. Move valve to end position CLOSED.
2. Push both lower discs with the symbols  $\equiv$  (OPEN) and  $\perp$  (CLOSED) towards each other. The disc with the arrow is thereby  $\Rightarrow$  is driven:

Figure 74: Setting position in CLOSED

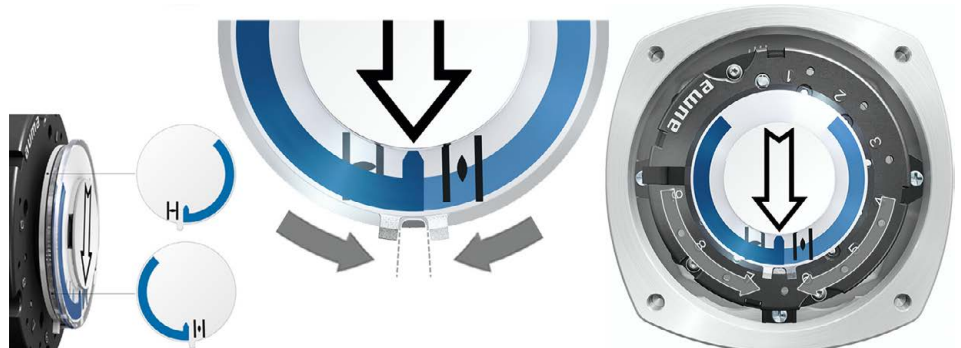

3. Move actuator to end position OPEN.
- ➔ The arrow  $\Rightarrow$  rotates in direction OPEN driving the indicator disc with symbol  $\equiv$  (OPEN) until the actuator stops in position OPEN.

Figure 75: Operation in direction OPEN (left) and position OPEN (right)



4. Check settings:
  - The setting of the mechanical position indicator is correct if the angle between the symbols  $\overline{\text{O}}$  (OPEN) and  $\overline{\text{I}}$  (CLOSED) ranges between approx. 120° and 280°.
  - If all three discs are turned at the same time, the indicator can be shifted in steps of 15°. Individual shifts of 5° are possible.
  - If the indicator is rotated too far (more than 280°) or if the angle is too small (below 120°), adapt the gear stage setting to the actuator turns/stroke. Refer to <Gear stage of the reduction gearing: test/set>.

### 11.2.2. Gear stage of the reduction gearing: test/set

The test/setting is only required if the mechanical position indicator cannot be correctly set.

1. Refer to table and check if turns/stroke correspond to the setting of the reduction gearing (stages 1– 9).

Table 27:

Turns of actuator per valve stroke and suitable reduction gearing setting		
for 1 – 500 turns/stroke [exceeding – to]	for 10 – 5,000 turns/stroke [exceeding – to]	Reduction gearing Stage
1.0 – 1.9	10 – 19	1
1.9 – 3.7	19 – 37	2
3.7 – 7.9	37 – 79	3
7.9 – 15.0	79 – 150	4
15.0 – 31.5	150 – 315	5
31.5 – 60.0	315 – 600	6
60.0 – 126	600 – 1,260	7
126 – 240	1,260 – 2,400	8
240 – 500	2,400 – 5,000	9

2. To modify settings, lift the lever at the reduction gearing and engage at the selected stage.

Figure 76: Set reduction gearing



### 11.3. Mechanical position indication via indicator mark (not self-adjusting)

Figure 77: Mechanical position indication via indicator mark



The mechanical position indicator shows the valve position via two indicator discs with symbols  $\text{O}$  (OPEN) and  $\text{C}$  (CLOSED). When correctly set, the symbols OPEN/CLOSED point to the indicator mark  $\blacktriangle$  at the cover in the end positions.

#### Setting elements

The position indications is housed in the actuator switch compartment. The switch compartment must be opened to perform any settings. Refer to <Switch compartment: open/close>.

#### 11.3.1. Mechanical position indicator: set

1. Move valve to end position CLOSED.
2. Turn lower indicator disc until symbol  $\text{C}$  (CLOSED) is in alignment with the  $\blacktriangle$  mark on the cover.



3. Move actuator to end position OPEN.
4. Hold lower indicator disc in position and turn upper disc with symbol  $\text{O}$  (OPEN) until it is in alignment with the  $\blacktriangle$  mark on the cover.



5. Move valve to end position CLOSED again.
6. Check settings:
  - If the symbol  $\text{C}$  (CLOSED) is no longer in alignment with  $\blacktriangle$  mark on the cover:
    - 6.1 Repeat setting procedure.
    - 6.2 Test/set gear stage of the reduction gearing.

#### 11.3.2. Gear stage of the reduction gearing: test/set

This test/setting is only required if the turns/stroke of the actuator were changed at a later date. The control unit may possibly have to be exchanged:

#### Information

The adjustable stroke range is indicated on the order data sheet (e.g. "1 – 500 turns/stroke").

1. Pull off indicator disc using a spanner as lever if required.



2. Refer to table and check if turns/stroke of the actuator correspond to the setting of the reduction gearing (stages 1– 9).  
If the setting is **not correct**: continue with step 3.  
If the setting is correct: continue with step 6.

Table 28:

<b>MS5.2 control unit (1 to 500 turns per stroke)</b>	
Turns/stroke above – to	Gear stage
1.0 – 1.9	1
1.9 – 3.9	2
3.9 – 7.8	3
7.8 – 15.6	4
15.6 – 31.5	5
31.5 – 62.5	6
62.5 – 125	7
125 – 250	8
250 – 500	9

Table 29:

<b>MS50.2 control unit (10 to 5,000 turns per stroke)</b>	
Turns/stroke above – to	Gear stage
10.0 – 19.5	1
19.5 – 39.0	2
39.0 – 78.0	3
78 – 156	4
156 – 315	5
315 – 625	6
625 – 1,250	7
1,250 – 2,500	8
2,500 – 5,000	9

3. Loosen screw [1].
4. Set crown wheel [2] to desired stage according to table.
5. Tighten screw [1].
6. Place indicator disc on shaft.
7. Set mechanical position indicator.

Figure 78: Control unit with reduction gearing

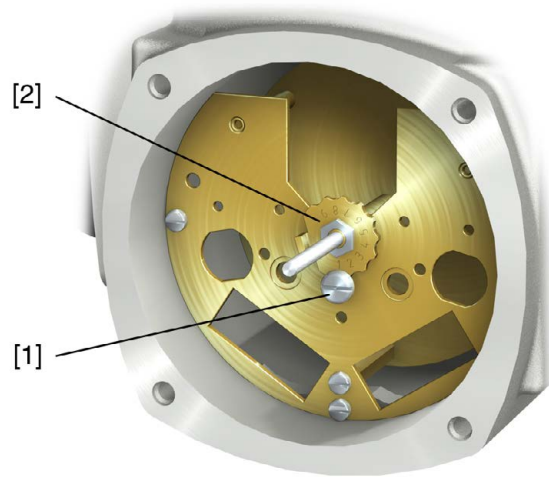

- [1] Screw
- [2] Crown wheel

## 12. Corrective action

### 12.1. Faults during commissioning

Table 30:

Faults during operation/commissioning		
Fault	Description/cause	Remedy
Mechanical position indicator cannot be set.	Reduction gearing is not suitable for turns/stroke of the actuator.	Set gear stage of the reduction gearing. The control unit might have to be exchanged.
In spite of correct setting of mechanical limit switching, actuator operates into the valve or actuator end position.	The overrun was not considered when setting the limit switching. The overrun is generated by the inertia of both the actuator and the valve and the delay time of the actuator controls.	<ul style="list-style-type: none"> <li>Determine overrun: Overrun = travel covered from switching off until complete standstill.</li> <li>Set limit switching again considering the overrun. (Turn handwheel back by the amount of the overrun)</li> </ul>
Handwheel rotates on the shaft without transmitting torque.	Actuator in version with overload protection for manual operation: Shear pin rupture due to excessive torque at handwheel.	Dismount handwheel. Replace overload protection and remount handwheel.

### 12.2. Fault indications and warning indications

**Faults** interrupt or prevent the electrical actuator operation. In the event of a fault, the display backlight is red.

**Warnings** have no influence on the electrical actuator operation. They only serve for information purposes. The display remains white.

**Collective signals** include further indications. They can be displayed via the **← Details** push button. The display remains white.

Table 31:

Faults and warnings via status indications in the display		
Indication on display	Description/cause	Remedy
S0001	Instead of the valve position, a status text is displayed.	For a description of the status texts, refer to Manual (Operation and setting).
S0005 Warnings	Collective signal 02: Indicates the number of active warnings.	For indicated value > 0: Press push button <b>← Details</b> . For details, refer to <Warnings and Out of specification> table.
S0006 Not ready REMOTE	Collective signal 04: Indicates the number of active signals.	For indicated value > 0: Press push button <b>← Details</b> . For details, refer to <Not ready REMOTE and Function check> table.
S0007 Fault	Collective signal 03: Indicates the number of active faults. The actuator cannot be operated.	For indicated value > 0: Press push button <b>← Details</b> to display a list of detailed indications. For details, refer to <Faults and Failure> table.
S0008 Out of specification	Collective signal 07: Indication according to NAMUR recommendation NE 107 Actuator is operated outside the normal operation conditions.	For indicated value > 0: Press push button <b>← Details</b> . For details, refer to <Warnings and Out of specification> table.



Faults and warnings via status indications in the display		
Indication on display	Description/cause	Remedy
S0009 Function check	Collective signal 08: Indication according to NAMUR recommendation NE 107 The actuator is being worked on; output signals are temporarily invalid.	For indicated value > 0: Press push button  Details. For details, refer to <Not ready REMOTE and Function check> table.
S0010 Maintenance required	Collective signal 09: Indication according to NAMUR recommendation NE 107 Recommendation to perform maintenance.	For indicated value > 0: Press push button  Details to display a list of detailed indications.
S0011 Failure	Collective signal 10: Indication according to NAMUR recommendation NE 107 Actuator function failure, output signals are invalid	For indicated value > 0: Press push button  Details to display a list of detailed indications. For details, refer to <Faults and Failure> table.

Table 32:

Warnings and Out of specification		
Indication on display	Description/cause	Remedy
Config. warning	Collective signal 06: Possible cause: Configuration setting is incorrect. The device can still be operated with restrictions.	Press push button  Details to display a list of individual indications. For a description of the individual signals, refer to Manual (Operation and setting).
Internal warning	Collective signal 15: Device warnings The device can still be operated with restrictions.	Press push button  Details to display a list of individual indications. For a description of the individual signals, refer to Manual (Operation and setting).
24 V DC external	The external 24 V DC voltage supply of the controls has exceeded the power supply limits.	Check 24 V DC voltage supply.
Wrn op.mode run time	Warning on time max. running time/h exceeded	<ul style="list-style-type: none"> <li>Check modulating behaviour of actuator.</li> <li>Check parameter <b>Perm. run time M0356</b>, re-set if required.</li> </ul>
Wrn op.mode starts	Warning on time max. number of motor starts (starts) exceeded	<ul style="list-style-type: none"> <li>Check modulating behaviour of actuator.</li> <li>Check parameter <b>Permissible starts M0357</b>, re-set if required.</li> </ul>
Failure behav. active	The failure behaviour is active since all required setpoints and actual values are incorrect.	Verify signals: <ul style="list-style-type: none"> <li>Setpoint E1</li> <li>Actual value E2</li> <li>Actual process value E4</li> <li>Check connection to master.</li> <li>Check (clear) status of master.</li> </ul>
Wrn input AIN 1	Warning: Loss of signal analogue input 1	Check wiring.
Wrn input AIN 2	Warning: Loss of signal analogue input 2	Check wiring.
Wrn setpoint position	Warning: Loss of signal setpoint position Possible causes: For an adjusted setpoint range of e.g. 4 – 20 mA, the input signal is 0 (signal loss). For a setpoint range of 0 – 20 mA, monitoring is not possible.	Check setpoint signal.
Op. time warning	The set time (parameter <b>Perm.op. time, manual M0570</b> ) has been exceeded. The preset operating time is exceeded for a complete travel from end position OPEN to end position CLOSED.	The warning indications are automatically cleared once a new operation command is executed. <ul style="list-style-type: none"> <li>Check valve.</li> <li>Check parameter <b>Perm.op. time, manual M0570</b>.</li> </ul>
Wrn controls temp.	Temperature within controls housing too high.	Measure/reduce ambient temperature.
Time not set	Real time clock has not yet been set.	Set time.
RTC voltage	Voltage of the RTC button cell is too low.	Replace button cell.
PVST fault	Partial Valve Stroke Test (PVST) could not be successfully completed.	Check actuator (PVST settings).

Warnings and Out of specification		
Indication on display	Description/cause	Remedy
PVST abort	Partial Valve Stroke Test (PVST) was aborted or could not be started.	Perform RESET or restart PVST.
Wrn no reaction	No actuator reaction to operation commands within the set reaction time.	<ul style="list-style-type: none"> <li>Check movement at actuator.</li> <li>Check parameter <b>Reaction time M0634</b>.</li> </ul>
Wrn FOC <sup>1)</sup>	Optical receiving signal (channel 1) incorrect (no or insufficient Rx receive level) or RS-485 format error (incorrect bit(s))	Check/repair FO cables.
Wrn FO cable budget <sup>1)</sup>	Warning: FO cable system reserve reached (critical or permissible Rx receive level)	Check/repair FO cables.
Wrn FOC connection <sup>1)</sup>	Warning FO cable connection is not available.	Fit FO cable connection.
Torque wrn OPEN	Limit value for torque warning in direction OPEN exceeded.	Check parameter <b>Wrn torque OPEN M0768</b> , re-set if required.
Torque wrn CLOSE	Limit value for torque warning in direction CLOSE exceeded.	Check parameter <b>Wrn torque CLOSE M0769</b> , re-set if required.
SIL fault <sup>2)</sup>	SIL sub-assembly fault has occurred.	Refer to separate Manual Functional Safety.
PVST required	Execution of PVST (Partial Valve Stroke Tests) is required.	
Maintenance required	Maintenance is required.	

- 1) For actuator controls with FOC connection  
2) For actuators controls in SIL version

Table 33:

Faults and Failure		
Indication on display	Description/cause	Remedy
Configuration error	Collective signal 11: Configuration error has occurred.	Press push button <b>Details</b> to display a list of individual indications. For a description of the individual signals, refer to Manual (Operation and setting).
Config. error REMOTE	Collective signal 22: Configuration error has occurred.	Press push button <b>Details</b> to display a list of individual indications. For a description of the individual signals, refer to Manual (Operation and setting).
Internal error	Collective signal 14: Internal error has occurred.	AUMA service Press push button <b>Details</b> to display a list of individual indications. For a description of the individual signals, refer to Manual (Operation and setting).
Torque fault CLOSE	Torque fault in direction CLOSE	Perform one of the following measures: <ul style="list-style-type: none"> <li>Issue operation command in direction OPEN.</li> <li>Set selector switch to position <b>Local control (LOCAL)</b> and reset fault indication via push button <b>RESET</b>.</li> <li>Execute reset command via fieldbus.</li> </ul>
Torque fault OPEN	Torque fault in direction OPEN	Perform one of the following measures: <ul style="list-style-type: none"> <li>Issue operation command in direction CLOSE.</li> <li>Set selector switch to position <b>Local control (LOCAL)</b> and reset fault indication via push button <b>RESET</b>.</li> <li>Execute reset command via fieldbus.</li> </ul>
Phase fault	<ul style="list-style-type: none"> <li>When connecting to a 3-ph AC system and with internal 24 V DC supply of the electronics: Phase 2 is missing.</li> <li>When connecting to a 3-ph or 1-ph AC system and with external 24 V DC supply of the electronics: One of the phases L1, L2 or L3 is missing.</li> </ul>	Test/connect phases.

Faults and Failure		
Indication on display	Description/cause	Remedy
Incorrect phase seq	The phase conductors L1, L2 and L3 are connected in the wrong sequence. Only applicable if connected to a 3-ph AC system.	Correct the sequence of the phase conductors L1, L2 and L3 by exchanging two phases.
Mains quality	Due to insufficient mains quality, the controls cannot detect the phase sequence (sequence of phase conductors L1, L2 and L3) within the pre-set time frame provided for monitoring.	<ul style="list-style-type: none"> <li>Check mains voltage. For 3-phase/1-phase AC current, the permissible variation of the mains voltage is <math>\pm 10\%</math> (option <math>\pm 30\%</math>). The permissible variation of the mains voltage is <math>\pm 5\%</math></li> <li>Check parameter <b>Tripping time M0172</b>, extend time frame if required.</li> </ul>
Thermal fault	Motor protection tripped	<ul style="list-style-type: none"> <li>Cool down, wait.</li> <li>If the fault indication display persists after cooling down:                             <ul style="list-style-type: none"> <li>Set selector switch to position <b>Local control</b> (LOCAL) and reset fault indication via push button <b>RESET</b>.</li> <li>Execute reset command via fieldbus.</li> </ul> </li> <li>Check fuses.</li> </ul>
Fault no reaction	No actuator reaction to operation commands within the set reaction time.	Check movement at actuator.
Poti Out of Range	Potentiometer is outside the permissible range.	Check device configuration: Parameter <b>Low limit Uspan M0832</b> must be less than parameter <b>Volt.level diff. potent. M0833</b> .
LPV not ready <sup>1)</sup>	LPV: Lift Plug Valve function The master actuator signals a fault	
Wrn input AIN 1	Loss of signal analogue input 1	Check wiring.
Wrn input AIN 2	Loss of signal analogue input 2	Check wiring.
Incorrect rotary direct.	Contrary to the configured direction of rotation and the active operation command, the motor turns into the wrong direction.	Check operation command control. For 3-phase AC current mains, activate phase monitoring (parameter <b>Adapt rotary dir. M0171</b> ). Check device configuration setting (parameter <b>Closing rotation M0176</b> ). To delete the fault indication: Disconnect actuator controls from the mains and perform reboot.
DMF fault OPEN <sup>2)</sup>	The torque in direction OPEN, measured at the output drive shaft using the torque measurement flange, is too high.	Check <b>DMF trip torque OP</b> parameter. Check <b>DMF fault level</b> parameter.
DMF fault CLOSE <sup>2)</sup>	The torque in direction CLOSE, measured at the output drive shaft using the torque measurement flange, is too high.	Check <b>DMF trip torque CL</b> parameter. Check <b>DMF fault level</b> parameter.
FQM collective fault <sup>3)</sup>	Collective signal 25:	Press push button <b>Details</b> to display a list of individual indications. For a description of the individual signals, refer to Manual (Operation and setting).

1) For lift plug valve product variant  
 2) For actuators equipped with torque measurement flange (DMF)  
 3) For actuators equipped with fail safe unit

Table 34:

Not ready REMOTE and Function check (collective signal 04)		
Indication on display	Description/cause	Remedy
Wrong oper. cmd	Collective signal 13: Possible causes: <ul style="list-style-type: none"> <li>Several operation commands (e.g. OPEN and CLOSE simultaneously, or OPEN and SET-POINT operation simultaneously)</li> <li>A setpoint is present and the positioner is not active</li> </ul>	<ul style="list-style-type: none"> <li>Check operation commands (reset/clear all operation commands and send one operation command only).</li> <li>Set parameter <b>Positioner</b> to <b>Function active</b>.</li> <li>Check setpoint.</li> </ul> Press push button  <b>Details</b> to display a list of individual indications. For a description of the individual signals, refer to Manual (Operation and setting).
Sel. sw. not REMOTE	Selector switch is not in position REMOTE.	Set selector switch to position REMOTE.
Service active	Operation via service interface (Bluetooth) and AUMA CDT service software.	Exit service software.
Disabled	Actuator is in operation mode Disabled.	Check setting and status of function <Local controls enable>.
EMCY stop active	The EMERGENCY stop switch has been operated. The motor control power supply (contactors or thyristors) is disconnected.	<ul style="list-style-type: none"> <li>Enable EMERGENCY stop switch.</li> <li>Reset EMERGENCY stop state by means of Reset command.</li> </ul>
EMCY behav. active	Operation mode EMERGENCY is active (EMERGENCY signal was sent). 0 V are applied at the EMERGENCY input.	<ul style="list-style-type: none"> <li>Detect cause for EMERGENCY signal.</li> <li>Verify failure source.</li> <li>Apply +24 V DC at EMERGENCY input.</li> </ul>
I/O interface	The actuator is controlled via the I/O interface (parallel).	Check I/O interface.
Handwheel active	Manual operation is activated.	Start motor operation.
FailState fieldbus	Fieldbus connection available, however no process data transmission by the master.	Verify master configuration
Local STOP	A local STOP is active. Push button STOP of local controls is operated.	Release push button STOP.
Interlock	An interlock is active.	Check interlock signal.
Interlock by-pass	By-pass function is interlocked.	Check states of main and by-pass valve.
PVST active	Partial Valve Stroke Test (PVST) is active.	Wait until PVST function is complete.
SIL function active <sup>1)</sup>	SIL function is active	

1) For actuators controls in SIL version

## 12.3. Fuses

### 12.3.1. Fuses within the actuator controls

#### F1/F2

Table 35:

Primary fuses F1/F2 (for power supply unit)		
G fuse	F1/F2	AUMA art. no.
Size	6.3 x 32 mm	
Reversing contactors Power supply ≤ 500 V	1 A T; 500 V	K002.277
Reversing contactors Power supply > 500 V	2 A FF; 690 V	K002.665
Thyristor units for motor power up to 1.5 kW	1 A T; 500 V	K002.277
Thyristor units for motor power up to 3.0 kW		
Thyristor units for motor power up to 5.5 kW		

#### F3 Internal 24 V DC supply

Table 36:

Secondary fuses F3 (internal 24 V DC supply)		
G fuse according to IEC 60127-2/III	F3	AUMA art. no.
Size	5 x 20 mm	
Voltage output (power supply unit) = 24 V	2.0 A T; 250 V	K006.106
Voltage output (power supply unit) = 115 V	2.0 A T; 250 V	K006.106

**F4**

Table 37:

Secondary fuse F4 (internal AC supply) <sup>1)</sup>		
G-fuse according to IEC 60127-2/III	F4	AUMA art. no.
Size	5 x 20 mm	
Voltage output (power supply unit) = 24 V	1.25 A T; 250 V	K001.184
Voltage output (power supply unit) = 115 V	—	—

1) Fuse for: Switch compartment heater, reversing contactor control, PTC tripping device (at 24 V AC only), at 115 V AC also control inputs OPEN, STOP, CLOSE

**F5**

Automatic reset fuse as short-circuit protection for external 24 V DC supply for customer (see wiring diagram)

**12.3.2. Fuse replacement**

**12.3.2.1. Replace fuses F1/F2**



**Electric shock due to presence of hazardous voltage!**

*Failure to observe this warning results in death or serious injury.*

→ Disconnect device from the mains before opening.

1. Remove electrical connection from actuator controls.

Figure 79:

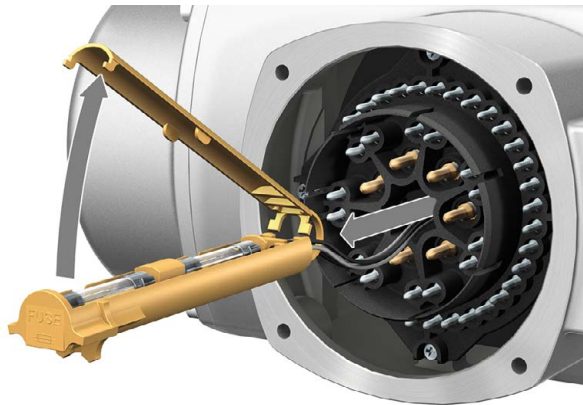

2. Pull fuse holder out of pin carrier, open fuse cover and replace old fuses by new ones.

**12.3.2.2. Test/replace fuses F3/F4**

1. Loosen screws [1] and remove cover [2] on the rear of the actuator controls. Figure 80:

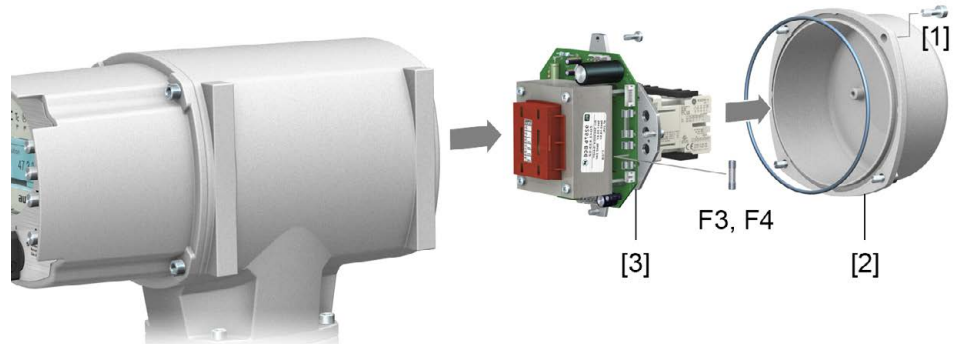

- Check fuses.**
2. The power supply unit has measuring points (solder pins) allowing to perform a resistance (continuity) measurement:

Table 38:

Checking	Measuring points
F3	MTP5 – MTP6
F4	MTP7 – MTP8

3. To replace defective fuses: Carefully loosen power supply unit [3] and pull out. (The fuses are on the equipped part of the power supply board.)

**NOTICE**

**Cable damage due to pinching!**

*Risk of functional failures.*

→ Carefully assemble power supply unit to avoid pinching the cables.

**12.3.3. Motor protection (thermal monitoring)**

In order to protect against overheating and impermissibly high surface temperatures at the actuator, PTC thermistors or thermoswitches are embedded in the motor winding. Motor protection trips as soon as the max. permissible winding temperature has been reached.

The actuator is switched off and the following signals are given:

- LED 3 (motor protection tripped) on the local controls is illuminated.
- The status indications **S0007** or **S0011 Failure** display a fault. The fault **Details** is displayed when selecting **Thermal fault**.

The motor has to cool down before operation can be resumed.

Depending on the parameter setting (motor protection behaviour), the fault signal is either automatically reset or the fault signal has to be acknowledged.

The acknowledgement is made:

- in selector switch position **Local control** (LOCAL) via push button **RESET**.
- In selector switch position **Remote control** (REMOTE) with Reset command via fieldbus.

**Proof-test motor protection**

Correct function of the motor protection can be tested.

**Information**

For weatherproof actuator controls mounted on wall bracket controlling an explosion-proof actuator, the functionality of the motor protection must be verified at the latest when performing the maintenance (refer to chapter <Servicing and maintenance>).

The test is performed by simulating the motor protection signal via actuator controls local controls:

Required user level: **Specialist (4)** or higher.

M ▶ **Diagnostics M0022**  
**TMS proof test M1950**

- Test procedure:**
1. Set selector switch to position **0** (OFF).
  2. Return to the main menu and select the simulation value in parameter **TMS proof test M1950**: Select **Thermal test**.
  3. Activate motor protection simulation: Press **Ok** push button.  
The safety function is correct if no fault signal is displayed.
  4. Reset simulation: Press **Ok** push button or exit the simulation menu and reset the selector switch to its initial position.

**13. Servicing and maintenance**



**Damage caused by inappropriate maintenance!**

- Servicing and maintenance must be carried out exclusively by suitably qualified personnel having been authorised by the end user or the contractor of the plant. Therefore, we recommend contacting our service.
- Only perform servicing and maintenance tasks when the device is switched off.

**AUMA  
Service & Support**

AUMA offers extensive service such as servicing and maintenance as well as customer product training. For the contact addresses, refer to our website ([www.auma.com](http://www.auma.com)).

**13.1. Preventive measures for servicing and safe operation**

The following actions are required to ensure safe device operation:

**6 months after commissioning and then once a year**

- Carry out visual inspection:  
Cable entries, cable glands, screw plugs, blanking plugs, etc. have to be checked for correct fit and sealing. If required, tighten cable glands and blanking plugs with torque in compliance with the manufacturer's specifications.  
Check actuator for damage as well as for grease or oil leakage.
- When deployed in areas where dust formation represents a potential explosion hazard, perform visual inspection for deposit of dirt or dust on a regular basis. Clean devices if required.
- Check fastening screws between actuator and gearbox/valve for tightness. If required, fasten screws while applying the tightening torques as indicated in chapter <Assembly>.
- When rarely operated: Perform test run.
- For devices with output drive type A: Press in Lithium soap EP multi-purpose grease on mineral oil base at the grease nipple with a grease gun.  
Figure 81: Output drive type A

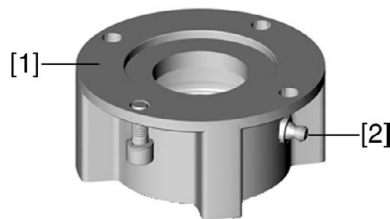

- [1] Output drive type A
- [2] Grease nipple

- Lubrication of the valve stem must be done separately.  
Exception: For output drive type A in version with stem lubrication (option), the stem is lubricated together with the output drive. If the valve manufacturer interval specifications are shorter for lubricating the valve, the shorter lubrication intervals of the valve manufacturer apply.

Table 39:

Grease quantities for bearing of output drive type A				
Output drive type	A 07.2	A 10.2	A 14.2	A 16.2
Quantity [g] <sup>1)</sup>	1.5	3	5	10

1) For grease with density  $r = 0.9 \text{ kg/dm}^3$



### 13.2. Maintenance

**Manual operation** During maintenance, the mechanical parts of the handwheel activation, in particular motor coupling and retaining spring, must be checked. Replace the parts in case of visible wear.

- Lubrication**
- In the factory, the gear housing is filled with grease.
  - Additional lubrication of the gear housing is not required during operation.
  - Grease change is performed during maintenance
    - Generally after 4 to 6 years for modulating duty.
    - Generally after 6 to 8 years if operated frequently (open-close duty).
    - Generally after 10 to 12 years if operated infrequently (open-close duty).
  - We recommend replacing the seals when changing the grease.

### 13.3. Disposal and recycling

Our devices have a long lifetime. However, they have to be replaced at one point in time. The devices have a modular design and may, therefore, easily be separated and sorted according to materials used, i.e.:

- Electronic scrap
- Various metals
- Plastic materials
- Greases and oils

The following generally applies:

- Greases and oils are hazardous to water and must not be released into the environment.
- Arrange for controlled waste disposal of the disassembled material or for separate recycling according to materials.
- Observe the national regulations for waste disposal.

## 14. Technical data

**Information** The following tables include standard and optional features. For detailed information on the customer-specific version, refer to the order-related data sheet. The technical data sheet can be downloaded from the Internet in both German and English at <http://www.auma.com> (please state the order number).

### 14.1. Technical data Multi-turn actuators

Features and functions	
Type of duty (Multi-turn actuators for open-close duty)	Standard: Short-time duty S2- 15 min, classes A and B according to EN ISO 22153
	Option: with 3-phase AC motor: Short-time duty S2- 30 min, classes A and B according to EN ISO 22153 For nominal voltage and +40 °C ambient temperature and at load with 35 % of the max. torque.
Type of duty (Multi-turn actuators for modulating duty)	Standard: Intermittent duty S4 - 25 %, class C according to EN ISO 22153
	Option: with 3-phase AC motor: Intermittent duty S4 - 50 %, class C according to EN ISO 22153 Intermittent duty S5 - 25 % (insulation class H required), class C according to EN ISO 22153 For nominal voltage and +40 °C ambient temperature and at modulating torque load.
Motors	Standard: 3-phase AC asynchronous motor, type IM B9 according to IEC 60034-7, IC410 cooling procedure according to IEC 60034-6
	Options: 1-phase AC motor with integral permanent split capacitor (PSC), type IM B9 according to IEC 60034-7, IC410 cooling procedure according to IEC 60034-6 1-phase AC motor with integral starting capacitor and solid state switch (CSIR), type IM B9 according to IEC 60034-7, IC410 cooling procedure according to IEC 60034-6 DC shunt motor, type IM B14 according to IEC 60034-7, IC410 cooling procedure according to IEC 60034-6 DC compound motor, type IM B14 according to IEC 60034-7, IC410 cooling procedure according to IEC 60034-6
Mains voltage, mains frequency	Refer to motor and actuator controls name plate Permissible variation of mains voltage: ±10 % Permissible variation of mains frequency: ±5 % (for 3-phase and 1-phase AC current)
Overvoltage category	Category III according to IEC 60364-4-443
Insulation class	Standard: F, tropicalized
	Option: H, tropicalized (with 3-phase AC motor)
Motor protection	Standard: Thermoswitches (NC), for 3-phase and 1-phase AC motors DC motors: Without
	Option: PTC thermistors (according to DIN 44082) PTC thermistors additionally require a suitable tripping device in the actuator controls.
Self-locking	Self-locking: Output speeds up to 90 rpm (50 Hz), 108 rpm (60 Hz) NOT self-locking: Output speeds from 125 rpm (50 Hz), 150 rpm (60 Hz) Multi-turn actuators are self-locking, if the valve position cannot be changed from standstill while torque acts upon the output drive.
Self-locking	Yes, multi-turn actuators are self-locking, if the valve position cannot be changed from standstill while torque acts upon the output drive.
Motor heater (option)	Voltages: 110 – 120 V AC, 220 – 240 V AC or 380 – 480 V AC for 3-phase AC motors
	Power depending on the size 12.5 – 25 W
Manual operation	Manual drive for setting and emergency operation, handwheel does not rotate during electrical operation.
	Option: Handwheel lockable Handwheel stem extension Power tool for emergency operation with square 30 mm or 50 mm
Indication for manual operation (option)	Indication whether manual operation is active/not active via single switch (1 change-over contact)
Electrical connection	Standard: AUMA plug/socket connector with screw-type connection Motor connection for DC motors, via separate motor terminal board if required
	Option: Terminals or crimp connection Gold-plated control plug (sockets and pins)

Features and functions	
Threads for cable entries	Standard: Metric threads
	Option: Pg-threads, NPT-threads, G-threads
Terminal plan	Terminal plan according to order number enclosed with delivery TPA11R0AA-101-000, DC shunt motor, motor connection on AUMA plug/socket connector TPA12R0AA-101-000, DC shunt motor, motor connection on separate terminal box TPA13R0AA-101-000, DC compound motor, motor connection on separate terminal box TPA14R0AA-101-000, DC compound motor, motor connection on AUMA plug/socket connector Depending on motor type/output speed. Refer to Electrical data SA 07.2 – SA 16.2 with DC motors TPA11R0AA-001-000, DC shunt motor, motor connection on AUMA plug/socket connector TPA12R0AA-001-000, DC shunt motor, motor connection on separate terminal box TPA13R0AA-001-000, DC compound motor, motor connection on separate terminal box TPA14R0AA-001-000, DC compound motor, motor connection on AUMA plug/socket connector Depending on motor type/output speed. Refer to Electrical data SAR 07.2 – SAR 16.2 with DC motors.
Valve attachment	Standard: B1 according to EN ISO 5210
	Option: A, B2, B3, B4, C, D according to EN ISO 5210 A, B, D, E according to DIN 3210 C according to DIN 3338
	Special valve attachments: AF, AK, AG, B3D, ED, DD, IB1, IB3 A prepared for permanent lubrication of stem

Electronic control unit	
Non-Intrusive setting	Magnetic limit and torque transmitter (MWG) Turns per stroke: 1 to 500 (standard) or 10 to 5,000 (option)
Position feedback signal	Via actuator controls
Torque feedback signal	Via actuator controls
Mechanical position indicator	Continuous self-adjusting indication with symbols OPEN and CLOSED
Running indication	Blinking signal via actuator controls
Heater in switch compartment	Resistance type heater with 5 W, 24 V AC

Service conditions	
Use	Indoor and outdoor use permissible
Mounting position	Any position
Installation altitude	≤ 2 000 m above sea level > 2,000 m above sea level, on request
Ambient temperature	Refer to actuator name plate
Humidity	Up to 100 % relative humidity across the entire permissible temperature range
Enclosure protection in accordance with IEC 60529	Standard: IP68 with AUMA DC motor IP68 with AUMA 3-phase AC motor IP68 with 1-phase AC motors of types VB..., AE..., VE..., AC..., VC... For special motors, differing enclosure protection is possible
	Option: Terminal compartment additionally sealed against interior of actuator (double sealed)
	According to AUMA definition, enclosure protection IP68 meets the following requirements: <ul style="list-style-type: none"> <li>• Depth of water: Maximum 8 m head of water</li> <li>• Continuous immersion in water: maximal 96 hours</li> <li>• Up to 10 operations during immersion</li> <li>• Modulating duty is not possible during immersion.</li> </ul>
Pollution degree according to IEC 60664-1	Pollution degree 4 (when closed), pollution degree 2 (internal)
Vibration resistance according to IEC 60068-2-6	2 g, 10 to 200 Hz (AUMA NORM), 1 g, 10 to 200 Hz (for actuator with mounted AM or AC AUMA actuator controls) Resistant to vibration during start-up or for failures of the plant. However, a fatigue strength may not be derived from this. Indications apply to actuator with AUMA 3-phase AC motor and AUMA plug/socket connector. They are not valid in combination with gearboxes.

Service conditions	
Corrosion protection	Standard: KS: Suitable for use in areas with high salinity, almost permanent condensation, and high pollution.
	Options: KX: Suitable for use in areas with extremely high salinity, permanent condensation, and high pollution. KX-G : same as KX, however aluminium-free version (outer parts)
Corrosion protection	Standard: KS: Suitable for use in areas with high salinity, almost permanent condensation, and high pollution.
	Option: KX: Suitable for use in areas with extremely high salinity, permanent condensation, and high pollution.
Coating	Two-layer powder coating Two-component iron-mica combination
Colour	Standard: AUMA silver-grey (similar to RAL 7037)
	Option: Available colours on request
Lifetime	AUMA multi-turn actuators meet or exceed the lifetime requirements of EN ISO 22153. Detailed information can be provided on request.
Noise level	< 72 dB (A)

Further information	
EU Directives	Machinery Directive 2006/42/EC Low Voltage Directive 2014/35/EU EMC Directive 2014/30/EU RoHS Directive 2011/65/EU RED Directive 2014/53/EU
Reference documents	Dimensions SA 07.2 – SA 16.2/SAR 07.2 – SAR 16.2 Dimensions SA 07.2 – SA 14.6/SAR 07.2 – SAR 14.6 Electrical data SA 07.2 – SA 16.2 Electrical data SAR 07.2 – SAR 16.2 Electrical data SA 07.2 – SA 14.6 Electrical data SAR 07.2 – SAR 14.6

## 14.2. Technical data Actuator controls

Features and functions	
Power supply	Refer to name plate Permissible variation of mains voltage: $\pm 10\%$ Permissible variation of mains voltage: $\pm 30\%$ (option) Permissible variation of mains frequency: $\pm 5\%$
External supply of the electronics (option)	24 V DC: $+20\%/-15\%$ Current consumption: Basic version approx. 250 mA, with options up to 500 mA For external electronics supply, the power supply of integral controls must have an enhanced isolation against mains voltage in compliance with IEC 61010-1 and the output power be limited to 150 VA.
Current consumption	Current consumption of the actuator controls depending on mains voltage: For permissible variation of mains voltage of $\pm 10\%$ : <ul style="list-style-type: none"> <li>• 100 to 120 V AC = max. 740 mA</li> <li>• 208 to 240 V AC = max. 400 mA</li> <li>• 380 to 500 V AC = max. 250 mA</li> <li>• 515 V AC = max. 200 mA</li> </ul> For permissible variation of mains voltage of $\pm 30\%$ : <ul style="list-style-type: none"> <li>• 100 to 120 V AC = max. 1,200 mA</li> <li>• 208 to 240 V AC = max. 750 mA</li> <li>• 380 to 500 V AC = max. 400 mA</li> <li>• 515 to 690 V AC = max. 400 mA</li> </ul>
Overvoltage category	Category III according to IEC 60364-4-443
Rated power	The actuator controls are designed for the nominal motor power, refer to motor name plate

Features and functions	
Switchgear	<p>Standard: Reversing contactors (mechanically and electrically interlocked) for AUMA power classes A1/A2</p> <p>Options: Reversing contactors (mechanically and electrically interlocked) for AUMA power class A3                      Thyristor unit for mains voltage up to 500 V AC (recommended for modulating actuators) for AUMA power classes B1, B2 and B3</p> <p>The reversing contactors are designed for a lifetime of 2 million starts. For applications requiring a high number of starts, we recommend the use of thyristor units.                      For the assignment of AUMA power classes, please refer to Electrical data on actuator</p>
Control and feedback signals	Via Profibus DP interface
Fieldbus interface with additional input signals (option)	<ul style="list-style-type: none"> <li>• 2 free analogue inputs (0/4 – 20 mA), 4 free digital inputs                             <ul style="list-style-type: none"> <li>- Signal transmission is made via fieldbus interface</li> </ul> </li> <li>• Inputs OPEN, STOP, CLOSE, EMERGENCY, I/O interface, MODE (via opto-isolator thereof OPEN, STOP, CLOSE, MODE with one common and EMERGENCY, I/O interface respectively without common)                             <ul style="list-style-type: none"> <li>- OPEN, STOP, CLOSE, EMERGENCY control inputs</li> <li>- I/O interface: Selection of control type (fieldbus interface or additional input signals)</li> <li>- MODE: Selection between open-close duty (OPEN, STOP, CLOSE) or modulating duty (0/4 – 20 mA position setpoint)</li> <li>- Additionally 1 analogue input (0/4 – 20 mA) for position setpoint</li> </ul> </li> <li>• Inputs OPEN, STOP, CLOSE, EMERGENCY, I/O interface, MODE (via opto-isolator thereof OPEN, STOP, CLOSE, MODE with one common and EMERGENCY, I/O interface respectively without common)                             <ul style="list-style-type: none"> <li>- OPEN, STOP, CLOSE, EMERGENCY control inputs</li> <li>- I/O interface: Selection of control type (fieldbus interface or additional input signals)</li> <li>- MODE: Selection between open-close duty (OPEN, STOP, CLOSE) or modulating duty (0/4 – 20 mA position setpoint)</li> <li>- Additionally 1 analogue input (0/4 – 20 mA) for setpoint position and 1 analogue input (0/4 – 20 mA) for actual process value</li> </ul> </li> </ul>
Control voltage/current consumption for control inputs	<p>Standard: 24 V DC, current consumption: approx. 10 mA per input</p> <p>Options: 48 V DC, current consumption: approx. 7 mA per input                      60 V DC, current consumption: approx. 9 mA per input                      100 – 125 V DC, current consumption: approx. 15 mA per input                      100 – 120 V AC, current consumption : approx. 15 mA per input</p> <p>All input signals must be supplied with the same potential.</p>
Status signals	Via Profibus DP interface
Fieldbus interface with additional output signals (option)	<p>Additional, binary output signals (only available in combination with additional input signals (option))</p> <ul style="list-style-type: none"> <li>• 6 programmable output contacts:                             <ul style="list-style-type: none"> <li>- 5 potential-free NO contacts with one common, max. 250 V AC, 1 A (resistive load)                                      Default configuration: End position CLOSED, end position OPEN, selector switch REMOTE, torque fault CLOSE, torque fault OPEN</li> <li>- 1 potential-free change-over contact, max. 250 V AC, 5 A (resistive load)                                      Default configuration: Collective fault signal (torque fault, phase failure, motor protection tripped)</li> </ul> </li> <li>• 6 programmable output contacts:                             <ul style="list-style-type: none"> <li>- 5 potential-free change-over contacts with one common, max. 250 V AC, 1 A (resistive load)</li> <li>- 1 potential-free change-over contact, max. 250 V AC, 5 A (resistive load)</li> </ul> </li> <li>• 6 programmable output contacts:                             <ul style="list-style-type: none"> <li>- 6 potential-free change-over contacts without one common, max. 250 V AC, 5 A (resistive load)</li> </ul> </li> <li>• 6 programmable output contacts:                             <ul style="list-style-type: none"> <li>- 4 mains failure proof potential-free NO contacts with one common, max. 250 V AC, 1 A (resistive load), 1 potential-free NO contact, max. 250 V AC, 1 A (resistive load), 1 potential-free change-over contact, max. 250 V AC, 5 A (resistive load)</li> </ul> </li> <li>• 6 programmable output contacts:                             <ul style="list-style-type: none"> <li>- 4 mains failure proof potential-free NO contacts, max. 250 V AC, 5 A (resistive load), 2 potential-free change-over contacts, max. 250 V AC, 5 A (resistive load),</li> </ul> </li> </ul> <p>All binary output signals must be supplied with the same potential.</p> <ul style="list-style-type: none"> <li>• Analogue output signal for position feedback                             <ul style="list-style-type: none"> <li>- Galvanically isolated position feedback 0/4 – 20 mA (load max. 500 Ω)</li> </ul> </li> </ul>

Features and functions	
Voltage output	<p>Standard: Auxiliary voltage 24 V DC: max. 100 mA for supply of control inputs, galvanically isolated from internal voltage supply.</p> <p>Option: Auxiliary voltage 115 V AC: max. 30 mA for supply of control inputs, galvanically isolated from internal voltage supply (Not possible in combination with PTC tripping device)</p>
Profibus DP-V1 (option)	Access to parameters, the electronic name plate and the operating and diagnostic data with acyclic write/read services
Profibus DP-V2 (option)	<p>Redundancy behaviour according to Profibus DP-V2 specification no. 2.212 (Primary and Backup with RedCom)</p> <p>Synchronisation of time between actuator controls and Profibus master with subsequent time stamp of the most important events such as malfunctions, end position and torque signals from actuator controls</p>
Redundancy (option)	<p>Requires Profibus DP-V2 (option)</p> <p>Redundant line topology with universal redundancy behaviour according to AUMA redundancy I or II</p> <p>Redundant line topology and redundancy behaviour according to Profibus DP-V2 specification no. 2.212 (Primary and Backup with RedCom)</p>
FO cable connection (option)	<ul style="list-style-type: none"> <li>• Connector types: ST or SC connector</li> <li>• FO cables <ul style="list-style-type: none"> <li>- Multi-mode: 62,5(50)/125 µm, range approx. 2.5 km (max. 2.0 dB/km)</li> <li>- Single-mode: 9/125 µm, range approx. 15 km (max. 0.4 dB/km)</li> </ul> </li> <li>• Topologies: Line, star and redundant loop (with single-channel Profibus DP interface)</li> <li>• Baud rate: up to 1.5 Mbit/s</li> <li>• Optical budget: <ul style="list-style-type: none"> <li>- Multi-mode: 13 dB</li> <li>- Single-mode: 17 dB</li> </ul> </li> <li>• Wave length: 1,310 nm</li> <li>• FO coupler by EKS required at DCS, reference addresses: AUMA or <a href="http://www.eks-engel.com">www.eks-engel.com</a></li> </ul>
Local controls	<p>Standard:</p> <ul style="list-style-type: none"> <li>• Selector switch: LOCAL - OFF - REMOTE (lockable in all three positions)</li> <li>• Push buttons OPEN, STOP, CLOSE, RESET <ul style="list-style-type: none"> <li>- Local STOP The actuator can be stopped via push button STOP of local controls if the selector switch is in position REMOTE. (Not activated when leaving the factory.)</li> </ul> </li> <li>• 6 indication lights: <ul style="list-style-type: none"> <li>- End position and running indication CLOSED (yellow), torque fault CLOSE (red), motor protection tripped (red), torque fault OPEN (red), end position and running indication OPEN (green), Bluetooth (blue)</li> </ul> </li> <li>• Graphic LC display: illuminated</li> </ul> <p>Option:</p> <ul style="list-style-type: none"> <li>• Special colours for the indication lights: <ul style="list-style-type: none"> <li>- End position CLOSED (green), torque fault CLOSE (blue), torque fault OPEN (yellow), motor protection tripped (violet), end position OPEN (red)</li> </ul> </li> </ul>
Bluetooth Communication interface	<p>Bluetooth Class II Chip, Version 2.1: With a range up to 10 m in industrial environments supports the SSP Bluetooth profile (Serial Port Profile).</p> <p>Required accessories:</p> <ul style="list-style-type: none"> <li>• AUMA CDT (Commissioning and Diagnostic Tool for Windows-based PC)</li> <li>• AUMA Assistant App (Commissioning and Diagnostic Tool)</li> </ul>

Features and functions		
Application functions	Standard:	<ul style="list-style-type: none"> <li>• Selectable type of seating, limit or torque seating for end position OPEN and end position CLOSED</li> <li>• Torque by-pass: Adjustable duration (with adjustable peak torque during start-up time)</li> <li>• Start and end of stepping mode as well as ON and OFF times can be set individually for directions OPEN and CLOSE, 1 to 1,800 seconds</li> <li>• Any 8 intermediate positions: can be set between 0 and 100 %, reaction and signal behaviour programmable</li> <li>• Running indication blinking: can be set</li> <li>• Positioner                             <ul style="list-style-type: none"> <li>- Position setpoint via Profibus DP interface</li> <li>- Programmable behaviour on loss of signal</li> <li>- Automatic adaptation of dead band (adaptive behaviour selectable)</li> <li>- Split range operation</li> <li>- Change-over between OPEN-CLOSE control and setpoint control possible via Profibus DP interface</li> </ul> </li> </ul>
	Options:	<ul style="list-style-type: none"> <li>• PID process controller: with adaptive positioner, via 0/4 – 20 mA analogue inputs for process setpoint and actual process value</li> <li>• Multiport valve: Up to 16 positions, signals (pulse or edge), accuracy &lt; 0.2 %</li> <li>• Automatic deblocking: Up to 5 operation trials, travel time in opposite direction can be set</li> <li>• Static and dynamic torque recording for both rotation directions with torque measurement flange as additional accessory</li> </ul>
Safety functions	Standard:	<ul style="list-style-type: none"> <li>• EMERGENCY operation (programmable behaviour)                             <ul style="list-style-type: none"> <li>- Via additional input (option, low active) or via fieldbus interface</li> <li>- Reaction can be selected: Stop, run to end position CLOSED, run to end position OPEN, run to intermediate position</li> <li>- Torque monitoring can be by-passed during EMERGENCY operation</li> <li>- Thermal protection can be by-passed during EMERGENCY operation (only in combination with thermoswitch within actuator, not with PTC thermistor).</li> </ul> </li> </ul>
	Options:	<ul style="list-style-type: none"> <li>• Release of local controls via fieldbus interface. Thus, actuator operation can be enabled or disabled via push buttons on local controls.</li> <li>• Local STOP                             <ul style="list-style-type: none"> <li>- The actuator can be stopped via push button Stop of local controls if the selector switch is in position REMOTE. (Not activated when leaving the factory.)</li> </ul> </li> <li>• Interlock for main/by-pass valve: Enabling the operation commands OPEN or CLOSE via fieldbus interface</li> <li>• EMERGENCY Stop push button (latching): Interrupts electrical operation, irrespective of the selector switch position</li> <li>• PVST (Partial Valve Stroke Test): programmable to check the function of both actuator and actuator controls: Direction, stroke, operation time, reversing time</li> </ul>
Monitoring functions		<ul style="list-style-type: none"> <li>• Valve overload protection: Adjustable, results in switching off and generates fault signal</li> <li>• Motor temperature monitoring (thermal monitoring): Results in switching off and generates fault signal</li> <li>• Monitoring the heater within actuator: Generates warning signal</li> <li>• Monitoring of permissible on-time and number of starts: Adjustable, generates warning signal</li> <li>• Operating time monitoring: Adjustable, generates warning signal</li> <li>• Phase failure monitoring: Results in switching off and generates fault signal</li> <li>• Automatic correction of rotation direction upon wrong phase sequence (3-ph AC current)</li> </ul>
Diagnostic functions		<ul style="list-style-type: none"> <li>• Electronic device ID with order and product data</li> <li>• Operating data logging: A resettable counter and a lifetime counter each for:                             <ul style="list-style-type: none"> <li>- Motor running time, number of starts, torque switch trippings in end position CLOSED, limit switch trippings in end position CLOSED, torque switch trippings in end position OPEN, limit switch trippings in end position OPEN, torque faults CLOSE, torque faults OPEN, motor protection trippings</li> </ul> </li> <li>• Time-stamped event report with history for setting, operation and faults</li> <li>• Status signals according to NAMUR recommendation NE 107: "Failure", "Function check", "Out of specification", "Maintenance required"</li> <li>• Torque characteristics (for version with MWG in actuator):                             <ul style="list-style-type: none"> <li>- 3 torque characteristics (torque-travel characteristic) for opening and closing directions can be saved separately.</li> <li>- Torque characteristics stored can be shown on the display.</li> </ul> </li> </ul>

Features and functions		
Motor protection evaluation	Standard:	Monitoring the motor temperature in combination with thermostats within actuator motor
	Options:	<ul style="list-style-type: none"> <li>Thermal overload relay in controls combined with thermostats within actuator</li> <li>PTC tripping device in combination with PTC thermistors within actuator motor</li> </ul>
Overvoltage protection (option)	Protection of the actuator and control electronics against overvoltages on the fieldbus cables of up to 4 kV	
Electrical connection	Standard:	AUMA plug/socket connector with screw-type connection
	Option:	Gold-plated control plug (sockets and plugs)
Threads for cable entries	Standard:	Metric threads
	Options:	<ul style="list-style-type: none"> <li>Pg-threads, NPT-threads, G-threads</li> <li>Terminals or crimp-type connection</li> </ul>
Wiring diagram	Refer to name plate	

Further options for Non-intrusive version with MWG in the actuator	
Setting of limit and torque switching via local controls	
Torque feedback signal	Via Profibus DP interface Galvanically isolated analogue output 0/4 – 20 mA (load max. 500 Ω). Option, only possible in combination with output contacts.

Settings/programming the Profibus DP interface	
Baud rate setting	Automatic baud rate recognition
Setting the fieldbus address	The Profibus DP address is set via the display of the device.
Configurable process representation via GSD file	For an optimum adaptation to the process control system, the process representation input (feedback signals) can be configured as desired.

General Profibus DP interface data			
Communication protocol	Profibus DP according to IEC 61158 and IEC 61784		
Network topology	Line (fieldbus) structure. When using repeaters, tree structures can also be implemented. Coupling and uncoupling of devices during operation without affecting other devices is possible.		
Transmission medium	Twisted, screened copper cable according to IEC 61158		
Profibus DP interface	EIA-485 (RS-485)		
Transmission rate/cable length	Baud rate (kbit/s)	Max. cable length (segment length) without repeater	Possible cable length with repeater (total network cable length):
	9.6 – 93.75	1,200 m	approx. 10 km
	187.5	1,000 m	approx. 10 km
	500	400 m	approx. 4 km
	1,500	200 m	approx. 2 km
Device types	DP master class 1, e.g. central controllers such as PLC, PC, ... DP master class 2, e.g. programming/configuration tools DP slave, e.g. devices with digital and/or analogue inputs/outputs such as actuators, sensors		
Number of devices	32 devices without repeater, with repeater expandable to 126		
Fieldbus access	Token-passing between masters and polling for slaves. Mono-master or multi-master systems are possible.		
Supported Profibus DP functions	Cyclic data exchange, sync mode, freeze mode, fail safe mode		
Profibus DP ident no.	0x0C4F:	Standard applications with Profibus DP-V0 and DP-V1	
	0x0CBD:	Applications with Profibus DP-V2	



Commands and signals of the Profibus DP interface	
Process representation output (command signals)	OPEN, STOP, CLOSE, position setpoint, RESET, EMERGENCY operation command, enable local controls, Interlock OPEN/CLOSE
Process representation input (feedback signals)	<ul style="list-style-type: none"> <li>• End positions OPEN, CLOSED</li> <li>• Actual position value</li> <li>• Actual torque value, requires MWG in actuator</li> <li>• Selector switch in position LOCAL/REMOTE</li> <li>• Running indication (directional)</li> <li>• Torque switches OPEN, CLOSED</li> <li>• Limit switches OPEN, CLOSED</li> <li>• Manual operation by handwheel or via local controls</li> <li>• Analogue (2) and digital (4) customer inputs</li> </ul>
Process representation input (fault signals)	<ul style="list-style-type: none"> <li>• Motor protection tripped</li> <li>• Torque switch tripped in mid-travel</li> <li>• One phase missing</li> <li>• Failure of analogue customer inputs</li> </ul>
Behaviour on loss of communication	The behaviour of the actuator is programmable: <ul style="list-style-type: none"> <li>• Stop in current position</li> <li>• Travel to end position OPEN or CLOSED</li> <li>• Travel to any intermediate position</li> <li>• Execute last received operation command</li> </ul>

Service conditions	
Use	Indoor and outdoor use permissible
Mounting position	Any position
Installation altitude	≤ 2 000 m above sea level > 2,000 m above sea level, on request
Ambient temperature	Refer to name plate of actuator controls
Humidity	Up to 100 % relative humidity across the entire permissible temperature range
Enclosure protection in accordance with IEC 60529	Standard: IP68 Option: Terminal compartment additionally sealed against interior of actuator controls (double sealed)  According to AUMA definition, enclosure protection IP68 meets the following requirements: <ul style="list-style-type: none"> <li>• Depth of water: Maximum 8 m head of water</li> <li>• Continuous immersion in water: maximal 96 hours</li> <li>• Up to 10 operations during immersion</li> <li>• Modulating duty is not possible during immersion.</li> </ul> For exact version, refer to actuator controls name plate.
Pollution degree according to IEC 60664-1	Pollution degree 4 (when closed), pollution degree 2 (internal)
Vibration resistance according to IEC 60068-2-6	1 g, from 10 Hz to 200 Hz Resistant to vibration during start-up or for failures of the plant. However, a fatigue strength may not be derived from this. (Not valid in combination with gearboxes)
Corrosion protection	Standard: KS: Suitable for use in areas with high salinity, almost permanent condensation, and high pollution. Option: KX: Suitable for use in areas with extremely high salinity, permanent condensation, and high pollution.
Coating	Double layer powder coating Two-component iron-mica combination
Colour	Standard: AUMA silver-grey (similar to RAL 7037) Option: Available colours on request

Accessories	
Wall bracket	For actuator controls mounted separately from the actuator, including plug/socket connector. Connecting cable on request. Recommended for high ambient temperatures, difficult access, or in case of heavy vibration during service. Cable length between actuator and actuator controls is max. 100 m. An MWG is required for position feedback.
Programming software	AUMA CDT (Commissioning and Diagnostic Tool for Windows-based PC) AUMA Assistant App (Commissioning and Diagnostic Tool)
Torque measurement flange DMF	Accessory for torque measurement for SA/SAR 07.2 – SA/SAR 16.2

Further information	
Weight	Approx. 7 kg (with AUMA plug/socket connector)
EU Directives	Machinery Directive 2006/42/EC Low Voltage Directive 2014/35/EU EMC Directive 2014/30/EU RoHS Directive 2011/65/EU

### 14.3. Tightening torques for screws

Table 40:

Tightening torques for screws		
Threads	Tightening torque [Nm]	
	Strength class	
	A2-70/A4-70	A2-80/A4-80
M6	7.4	10
M8	18	24
M10	36	48
M12	61	82
M16	150	200
M20	294	392
M30	1,015	1,057
M36	1,769	2,121

## 15. Spare parts

### 15.1. Multi-turn actuators SA 07.2 – SA 16.2/SAR 07.2 – SAR 16.2

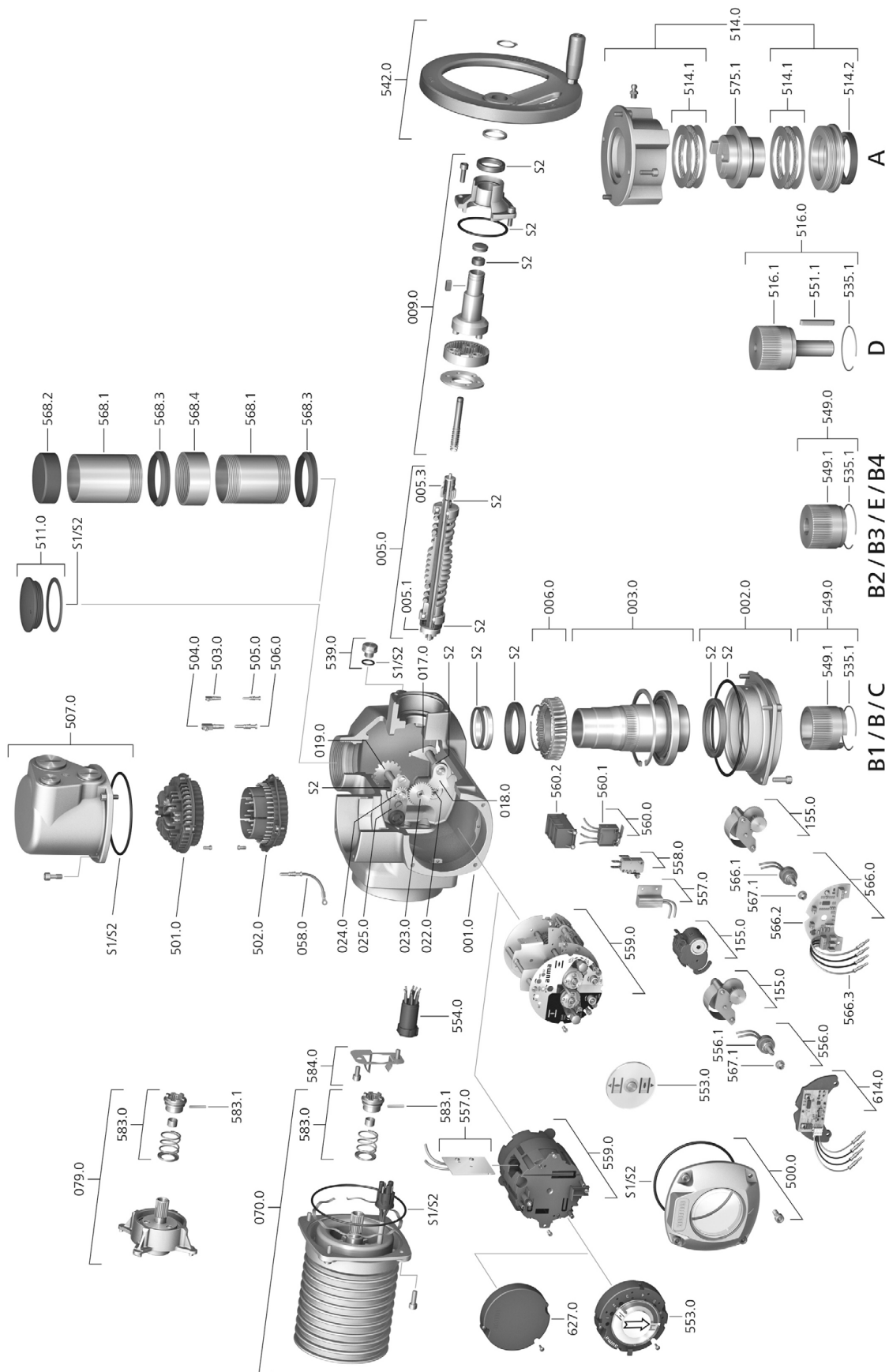

Spare parts

Please state device type and our order number (see name plate) when ordering spare parts. Only original AUMA spare parts should be used. Failure to use original spare parts voids the warranty and exempts AUMA from any liability. Representation of spare parts may slightly vary from actual delivery.

Ref. no.	Designation	Type	Ref. no.	Designation	Type
001.0	Housing	Sub-assembly	542.0	Handwheel with ball handle	Sub-assembly
002.0	Bearing flange	Sub-assembly	549.0	Output drive types B/B1/B2/B3/B4/C/E	Sub-assembly
003.0	Hollow shaft	Sub-assembly	549.1	Output drive sleeve B/B1/B2/B3/B4/C/E	Sub-assembly
005.0	Drive shaft	Sub-assembly	551.1	Parallel key	
005.1	Motor coupling		553.0	Mechanical position indicator	Sub-assembly
005.3	Manual drive coupling		554.0	Socket carrier for motor plug/socket connector with cable harness	Sub-assembly
006.0	Worm wheel		556.0	Potentiometer as position transmitter	Sub-assembly
009.0	Manual gearing	Sub-assembly	556.1	Potentiometer without slip clutch	Sub-assembly
017.0	Torque lever	Sub-assembly	557.0	Heater	
018.0	Gear segment		558.0	Blinker transmitter including pins at wires (without impulse disc and insulation plate)	Sub-assembly
019.0	Crown wheel		559.0–1	Electromechanical control unit with switches, including torque switching heads	Sub-assembly
022.0	Drive pinion II for torque switching	Sub-assembly	559.0–2	Electronic control unit with magnetic limit and torque transmitter (MWG)	Sub-assembly
023.0	Output drive wheel for limit switching	Sub-assembly	560.0–1	Switch stack for direction OPEN	Sub-assembly
024.0	Drive wheel for limit switching	Sub-assembly	560.0–2	Switch stack for direction CLOSE	Sub-assembly
025.0	Locking plate	Sub-assembly	560.1	Switch for limit/torque	Sub-assembly
058.0	Cable for protective earth	Sub-assembly	560.2–1	Switch case for direction OPEN	
070.0	Motor (only for V... motors incl. ref. no. 079.0)	Sub-assembly	560.2–2	Switch case for direction CLOSE	
079.0	Planetary gearing for motor drive (only for V... motors)	Sub-assembly	566.0	RWG position transmitter	Sub-assembly
155.0	Reduction gearing	Sub-assembly	566.1	Potentiometer for RWG without slip clutch	Sub-assembly
500.0	Cover	Sub-assembly	566.2	Position transmitter board for RWG	Sub-assembly
501.0	Socket carrier (complete with sockets)	Sub-assembly	566.3	Cable set for RWG	Sub-assembly
502.0	Pin carrier without pins	Sub-assembly	567.1	Slip clutch for potentiometer	Sub-assembly
503.0	Socket for controls	Sub-assembly	568.1	Stem protection tube (without cap)	
504.0	Socket for motor	Sub-assembly	568.2	Protective cap for stem protection tube	
505.0	Pin for controls	Sub-assembly	568.3	V-seal	
506.0	Pin for motor	Sub-assembly	568.4	Threaded sleeve	
507.0	Cover for electrical connection	Sub-assembly	575.1	Stem nut for output drive type A	
511.0	Threaded plug	Sub-assembly	583.0	Motor coupling on motor shaft	Sub-assembly
514.0	Output drive type A (without stem nut)	Sub-assembly	583.1	Pin for motor coupling	
514.1	Axial needle roller bearing	Sub-assembly	584.0	Retaining spring for motor coupling	Sub-assembly
514.2	Radial seal for output drive type A		614.0	EWG position transmitter	Sub-assembly
516.0	Output drive type D	Sub-assembly	627.0	MWG 05.03 cover	
516.1	Output drive shaft D		S1	Seal kit, small	Set
535.1	Snap ring		S2	Seal kit, large	Set
539.0	Screw plug	Sub-assembly			

**15.2. AC 01.2 actuator controls with SD electrical connection**

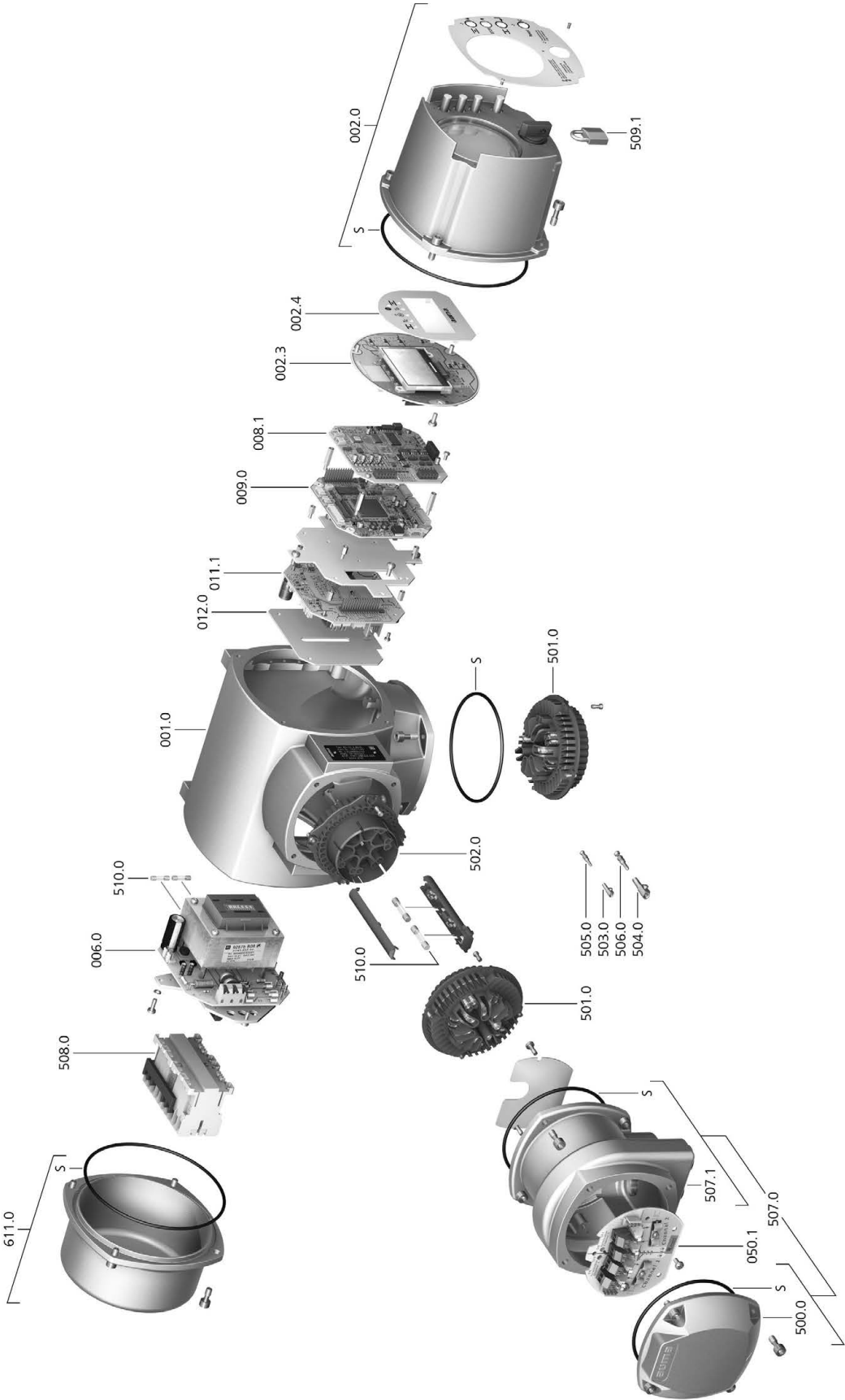

Spare parts

Please state device type and our order number (see name plate) when ordering spare parts. Only original AUMA spare parts should be used. Failure to use original spare parts voids the warranty and exempts AUMA from any liability. Representation of spare parts may slightly vary from actual delivery.

Ref. no.	Designation	Type
001.0	Housing	Sub-assembly
002.0	Local controls	Sub-assembly
002.3	Local controls board	Sub-assembly
002.4	Face plate for display	
006.0	Power supply unit	Sub-assembly
008.1	Fieldbus board	
009.0	Logic board	Sub-assembly
011.1	Relay board	Sub-assembly
012.0	Option board	
050.1	Fieldbus connection board	Sub-assembly
500.0	Cover	Sub-assembly
501.0	Socket carrier (complete with sockets)	Sub-assembly
502.0	Pin carrier without pins	Sub-assembly
503.0	Socket for controls	Sub-assembly
504.0	Socket for motor	Sub-assembly
505.0	Pin for controls	Sub-assembly
506.0	Pin for motor	Sub-assembly
507.0	Electrical connection for fieldbus without connection board (050.1)	Sub-assembly
507.1	Frame for electrical connection	Sub-assembly
508.0	Switchgear	Sub-assembly
509.1	Padlock	Sub-assembly
510.0	Fuse kit	Kit
611.0	Cover	Sub-assembly
S	Seal kit	Set







## Index

### A

Accessories (electrical connection)	36
Accessories for assembly	24
Actual value - indication on display	49
Actuator controls terminal plan	10
Actuator operation from remote	41
Actuator terminal plan	10, 11
Ambient temperature	9, 10, 83, 89
Analogue signals	56
Applications	5
Assembly	17
Assistant App	11
AUMA Assistant App	8, 11
AUMA Cloud	8

### B

Blanking plug	27
Bluetooth	8

### C

Cable entries	83
Cable glands	27
Cables	27
Cable set	36
CDT	8
Coating	89
Colour	89
Commissioning	5
Commissioning (indications on display)	47
Connecting cable	36
Connecting cables	27
Control	10, 11
Control inputs Potential	27
Control voltage	11
Corrective action	72
Corrosion protection	15, 84, 84, 89
Cross section (fieldbus cable)	28
Current consumption	26
Current type	10, 26

### D

Data Matrix code	11
Digital outputs	55
Direct display via ID	43
Direction of rotation	63, 64
Directives	5
Display (indications)	47
Disposal	81
Double sealed	37

### E

Earth connection	38
Electrical connection	26, 82
EMC	28
Enclosure protection	9, 10, 10, 83, 89
Error - indication on display	48

### F

Failure - indication on display	52
Fault	72
Fault - indication on display	51
Features and functions	88
Fieldbus address	62
Fieldbus cable	28
Fieldbus cables	34
Flange size	11
Frequency range	26
Function check - indication on display	51
Fuses	76

### G

GSD file	55
----------	----

### H

Handwheel	17
Heating system	27
Hollow shaft	64
Humidity	83

### I

Incorrect entry	45
Indication lights	53
Indications	47
Indications on display	47
Indicator disc	54, 67, 69
Indicator mark	54
Input current	11
Input signal	11
Input signals Potential	27
Inspection certificate	11
Installation altitude	89
Insulation class	10, 82
Intermediate frame	37
Intermediate position indication via LEDs	53
Intrusive	7

### L

Language in the display	45
LEDs (indication lights)	53
Lifetime	84
Local actuator operation	40
Local control	40
Local controls	40
Local setting	41
Lubrication	81

<b>M</b>		<b>P</b>	
Main menu	42	Parking frame	37
Mains frequency	10, 10, 82	Password	43
Mains voltage	10, 10, 26, 82	Password change	44
Maintenance	5, 80, 81	Password entry	44
Maintenance required - indication on display	52	Positioner - indication on display	49
Manual operation	39, 82	Position indicator	54, 54, 67, 69
Mechanical position indicator	54, 54, 67, 69	Position transmitter	11
Mechanical position indicator (self-adjusting)	67	Power class	10
Menu navigation	41	Power class for switchgear	11
Motor heater	82	Power factor	10
Motor operation	40	Power supply of electronics	26
Motor protection	10, 82	Production, year	11
Motors	82	Protection on site	26
Motor type	10	Protective measures	5
Mounting position	89	Push-to-run operation	41
<b>N</b>		<b>Q</b>	
Name plate	9	Qualification of staff	5
Nominal current	10	<b>R</b>	
Nominal power	10	Range of application	5
Non-Intrusive	7	Recycling	81
Not ready REMOTE - indication on display	51	Reduction gearing	69
<b>O</b>		reductions	27
Operating the actuator from local controls	40	Remote actuator operation	41
Operation	5, 39	Residual current device (RCD)	27
Operation commands - indications on display	49	Running indication	54, 54
Order number	9, 10, 11		
Out of specification - indication on display	51		
Output contacts	55		
Output drive type A	18		
Output drive types	18		
Output drive types B	22		
Output signals	55		
Output signals Potential	27		
Output speed	9, 10		
Overload protection	39		
Overvoltage category	82, 84		

<b>S</b>		<b>W</b>	
Safety instructions	5	Wall bracket	36
Safety instructions/warnings	5	Warnings - indication on display	50
Safety measures	27	Wire diameter (fieldbus cable)	28
Safety standards	27	Wiring diagram	11, 26
Screening (fieldbus cable)	28		
Screw plugs	27	<b>Y</b>	
Self-locking	82, 82	Year of production	11
Self-retaining	41		
Serial number	9, 10, 11		
Service	80		
Servicing	80		
Setpoint - indication on display	49		
Short-circuit protection	26		
Signals	55		
Signals (analogue)	56		
Size	11		
Slave address	62		
Spare parts	91		
Standards	5		
Status menu	42		
Status signals	55		
Status signals Potential	27		
Stem	64		
Stem nut	21		
Stem protection tube	24		
Storage	15		
Supply networks	26		
Support	80		
<b>T</b>			
Technical data	82		
Temperature protection	10		
Terminal plan	26, 83		
Test run	62		
Timeout	45		
Torque - indication on display	48		
Torque range	9		
Torque switching	58		
Transport	13		
Type	11		
Type designation	9, 10		
Type of duty	10, 82		
Type of lubricant	9		
Type of networks	26		
<b>U</b>			
User level	43		
<b>V</b>			
Valve attachment	18, 83		
Valve position - indication on display	48		
Valve stem	24		
Vibration resistance	89		
Voltage range	26		

**auma**<sup>®</sup>

*Solutions for a world in motion*

**AUMA Riester GmbH & Co. KG**

P.O. Box 1362

**DE 79373 Muellheim**

Tel +49 7631 809 - 0

Fax +49 7631 809 - 1250

info@auma.com

www.auma.com