



## PMV Valve Control System



**GB**

**Manufacturers declaration**

We hereby confirm that the appliances described in this sheet has been manufactured in compliance with the applicable standards and is intended for installation in a machine/application, and that commissioning is strictly prohibited until evidence has been provided that the machine/application in question is also in compliance with

EC directive 2006/42/EC, 2006/95/EC and 2004/108/EC.

This manufacturers declaration is applicable to the following PMV series:

F5.

**D**

**Hersteller-Erklärung**

Hiermit erklären wir, daß die in diesem Blatt beschriebenen Geräte entsprechend den gültigen Normen gebaut und zum Einbau in eine Maschine oder Applikation bestimmt sind, sowie daß deren

Inbetriebnahme so lange untersagt ist, bis festgestellt wurde, daß diese

Maschine/ Applikation ebenfalls der EG-Richtlinie

2006/42/EC, 2006/95/EC und 2004/108/EC.

Diese Herstellererklärung hat für folgende PMV-Serien Gültigkeit:

F5.

**F**

**Déclaration de fabricant**

Nous déclarons par la présente que les appareils décrits sur cette page sont construits en conformité avec les normes en vigueur et qu'ils sont destinés à être montés dans une machine ou une application, nous déclarons également que leur mise en service est interdite tant qu'il n'a pas été constaté que cette machine/application satisfait

également à la directive 2006/42/EC, 2006/95/EC et 2004/108/EC.

Cette déclaration de fournisseur est valable pour les types d'appareils PMV suivants:

F5.



*Mr. Jan-Eric Andersson*  
*President, Palmstiernas International AB*

## PMV Feedback module storage and handling procedures

PMV feedback modules are precision instruments which should be stored and handled accordingly to avoid problems or damage. Feedback modules contain electronic components which can be damaged by exposure to water. Appropriate precautions should be taken to protect units while in storage.

### Warehouse storage

-Stored in original PMV shipping containers, units should be stored in an environmentally controlled area, i.e. clean, cool (15-26°C, 60-80°F) and dry, out of direct sunlight or weather exposure.

### Field storage

- If feedback units must be stored outdoors, make sure front covers are tightened, all conduit entries are sealed and that units not are exposed to direct sunlight, rain or snow.

### Potential damage mechanism

When units are stored in hot, humid climates, the daily heating/cooling cycle will cause air to expand/contract and be drawn in and out of the feedback housing through ports left open. Dependent on the local temperature variations, humidity and dew points and time in storage, condensation could occur and accumulate inside causing erratic operation or failure due to water and corrosion. The potential for condensation damage is especially high in southern climates and aggravated if units are exposed to direct sunlight.

For further assistance, please contact you nearest PMV office.

### Storage Seal

F5 is supplied with conduit entry points sealed. The seal is only a storage seal, not to be used as seal when F5 is in operation.

If Storage Seal is removed or damaged, make sure conduit entry points are resealed before further shipping or storage.

Use proper cable glands or vapour proof tape.

Mount F5 on positioner P5/EP5 or actuator /valve package. Remove Storage Seal for conduit entry  $E_1$  &  $E_2$ , make electrical connections, install proper cable glands or plugs to ensure the units sealing.

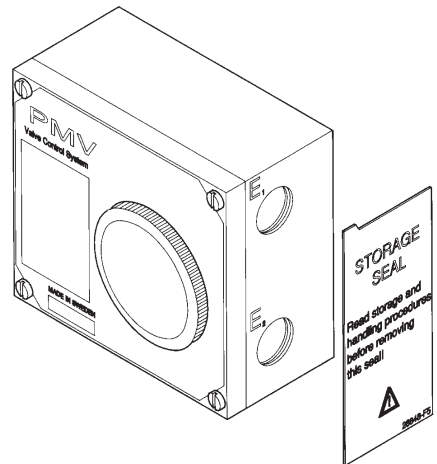

## Description

The PMV F5 is a feedback unit uniquely designed to mount on top of the PMV P5, EP5 or P-2000 positioners with minimum parts required. The F5 can also be mounted on actuators with an additional mounting kit. The F5 is available in two different enclosures, standard or explosion proof.



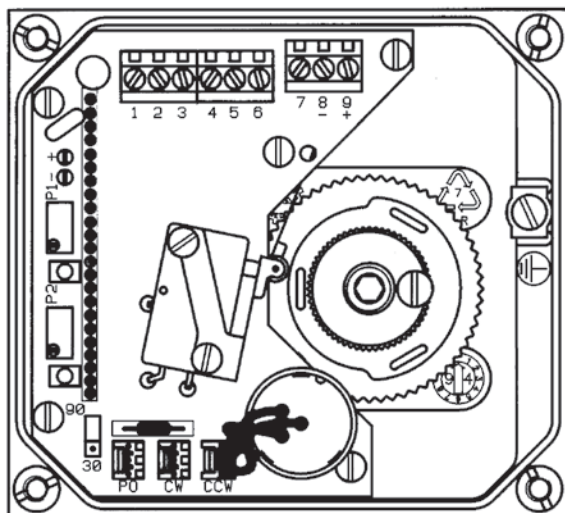

The standard enclosure for F5 offers a gasketed NEMA 4/ IP66 enclosure with optional American and European intrinsically safe approvals. The explosion proof version is approved NEMA 7 / IP66 and carries North American and European approvals. Both enclosures can be furnished with Namur sensors, mechanical or proximity switches, potentiometer or 4-20 mA position transmitter or a combination of these items.



# Product label

## F5 IS Intrinsically safe

**F5-SW/MEC-420 FEEDBACK UNIT**  
 INTRINSICALLY SAFE / SECURITE INTRINSEQUE-Exia  
 EEx ia IIC T4 C.II Div1 Groups C-D T3C  
 Electrical rating: 28V DC, 24mA  
 When installed in accordance with installation drawing: F5-2-4-9516  
 WARNING! Substitution of components may impair intrinsic safety.  
 AVERTISSEMENT! La substitution de composants peut compromettre la securite intrinseque.

LCIE 03ATEX6103X   II 1G   Prod.year-Serial number



FLOWSERVE, SWEDEN  
 PALMSTIERNA INTERNATIONAL AB SOLNA

29241

PART NO.	DESCRIPTION	MATERIAL	DIMENSION	ANNOTATION
H13	ISO 2768-m	Ra: 6,3		
	PMV Feedback Unit		REV BY: MR	DATE: 980108
	F5		REV BY: MR	DATE: 980108
PALMSTIERNA INTERNATIONAL AB				29241
KORTA GATAN 9, SE-171 84 SOLNA, SWEDEEN - Tel: +46(0)8 555 106 00-Fax: +46(0)8 555 106 00 - www.palmi.se				

## F5 EX Explosion proof

**EXPLOSION PROOF FEEDBACK UNIT F5EX-MEC-420**  
 Class I & II Division 1 Groups B-G NEMA 4X  
 T6(T<sub>amb</sub> +122°F) T5(T<sub>amb</sub> +140°F) T4(T<sub>amb</sub> +176°F)  
 Electrical rating: max 28V DC, max 24mA, max 1W APPROVED

EEx d IIB+H<sub>2</sub> T6(T<sub>amb</sub> +50°C) T5(T<sub>amb</sub> +60°C) T4(T<sub>amb</sub> +80°C) IP66  
  II 2G LCIE 03ATEX 6137  
 Electrical rating: max 28V DC, 0-20mA, max 1W

DO NOT OPEN WHILE ENERGIZED! / NE PAS OUVRIER SOUS TENSION!  
 TORQUE COVER BOLTS TO 5.2 lb\*ft / 7Nm Prod.year-Serial number

FLOWSERVE, SWEDEN  
 PALMSTIERNA INTERNATIONAL AB SOLNA

29245

PART NO.	DESCRIPTION	MATERIAL	DIMENSION	ANNOTATION
H13	ISO 2768-m	Ra: 6,3		
	PMV Feedback Unit		REV BY: MR	DATE: 980408
	F5EX		REV BY: MR	DATE: 980408
PALMSTIERNA INTERNATIONAL AB				29245
KORTA GATAN 9, SE-171 84 SOLNA, SWEDEEN - Tel: +46(0)8 555 106 00-Fax: +46(0)8 555 106 00 - www.palmi.se				

# Modell code

## F5 feedback unit model code

Not for Hazardous areas

### Model No

F 5 Feedback unit, to be installed on top of P5/EP5, no cover incl.\*

### Electrical connection

G 2 x M20 x 1,5

N 2 x 1/2" NPT

### Surface treatment

U Epoxy, ED

M Tufam

### Switches

M E C 2 x SPDT switches

N A M 2 X Namur sensors

P X Y 2 x SPDT proximity switches

### Feedback

X X X None

P O T Potentiometer, 5 kOhm

P 1 K Potentiometer, 1 kOhm

P 1 8 Potentiometer, 180 deg

4 2 0 4-20 mA transmitter

T 1 8 4-20 mA transmitter, 180deg

T 2 7 4-20 mA transmitter, 270 deg

### Spindle

0 0 For installation on P5/EP5, no other spindle available.

### Temperature

Z Nitrile, NBR -40 to +85 deg C

F	5		
---	---	--	--

 - 

--	--	--	--

 - 

0	0
---	---

 - Z

\* For stand alone mounting, select F5IS

## F5IS & F5EX feedback unit model code

### Model No

F 5 I S Feedback unit, intrinsically safe ATEX, CSA, FM, incl. cover

F 5 E X Feedback unit, explosion proof, ATEX, CSA, FM, incl. cover

### Electrical connection

G\* 2 x M20 x 1,5

N 1/2" NPT x 2

### Surface treatment

U Epoxy, ED

M\* Tufam

### Switches

M E C 2 x SPDT switches

N A M 2 X Namur sensors

P X Y 2 x SPDT proximity switches

### Feedback

X X X None

P O T Potentiometer, 5 kOhm

P 1 K Potentiometer, 1 kOhm

P 1 8 Potentiometer, 180 deg

4 2 0 4-20 mA transmitter

T 1 8 4-20 mA transmitter, 180 deg

T 2 7 4-20 mA transmitter, 270

### Spindle

0 0 For installation on P5/EP5

2 3 Rotary, Namur, VDI/VE 3845

? ? More spindles are available, contact PMV

### Frontcover

P V 9 90 deg, 0-100% scale

P V 6 60 deg, 0-100% scale

P V 4 45 deg, 0-100% scale

P V 3 30 deg, 0-100% scale

P V 0 Blank, no scale

### Function

D Direct

R Reverse

### Indicator

A Indicator

B No indicator

H Dome style

T Temperature

Z Nitrile, NBR -40 to +85 deg C

F	5			
---	---	--	--	--

 - 

--	--	--	--

 - 

--	--	--	--

 - P V 

--	--	--	--

 - Z



## Mounting on P5 or EP5

- See [www.pmv.nu/downloads](http://www.pmv.nu/downloads) for video clip.
- Remove the front cover and the indicator from the positioner.
- Loosen and remove the Allen head screw (3) (5mm hex-wrench)
- Install drive coupling (4) on the positioner shaft, secure it with screw (3)
- Check that F5is fitted with 4 nos of screws 5 and O-ring 9, install the F5 on top of the positioner unit, make sure that the coupling is properly engaged before tightening the four screws 5.
- Make connections and calibrate.
- Reinstall indicator 2 and front cover 1 on the F5, tighten 1,5-2 Nm

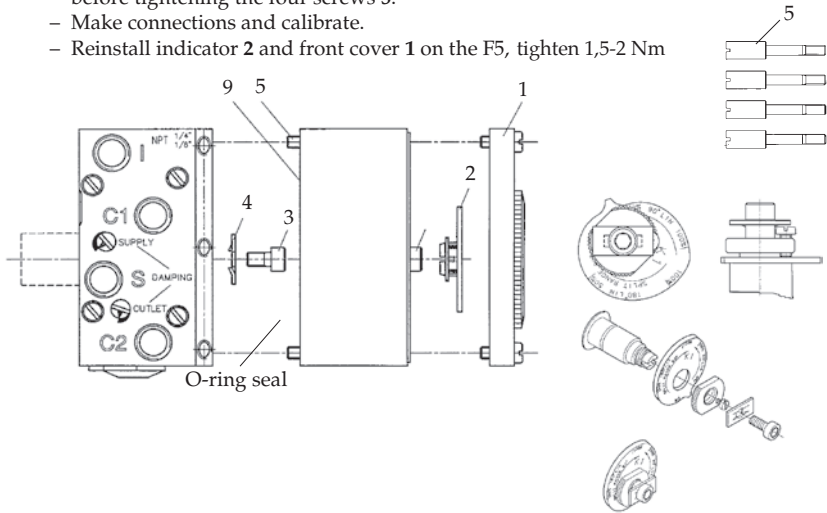

### Mounting F5 on actuator (On/Off control valves)

Install the spindle adaptor 1 into F5 shaft, make sure that a spring clip 2 is fitted. A solid click should be heard when the spindle adaptor is properly installed into the F5 shaft.

Mount F5 on the actuator using a mounting kit and the ISO F05 mounting holes on the bottom of the F5. Make sure that the F5 spindle is properly aligned on top of the actuator.

Check that the four fasteners 3 are installed into F5.

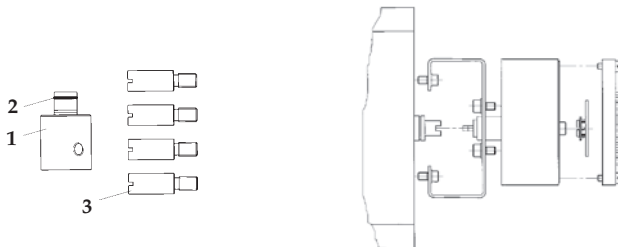

## Mounting on P-2000/P-2020

- Remove front cover, indicator and cam nut from the positioner
- Replace the cam nut with coupling 1, calibrate the positioner.
- Check that the gasket is fitted to the bottom of plate 2, install screws 5 (3x long, 1x short) plastic washer 6 and O-rings 7.
- Secure the F5 to the plate 2 with screws 3.
- Install assembly onto the positioner, make sure that coupling 1 is properly engaged.
- Make electrical connections and calibrate.

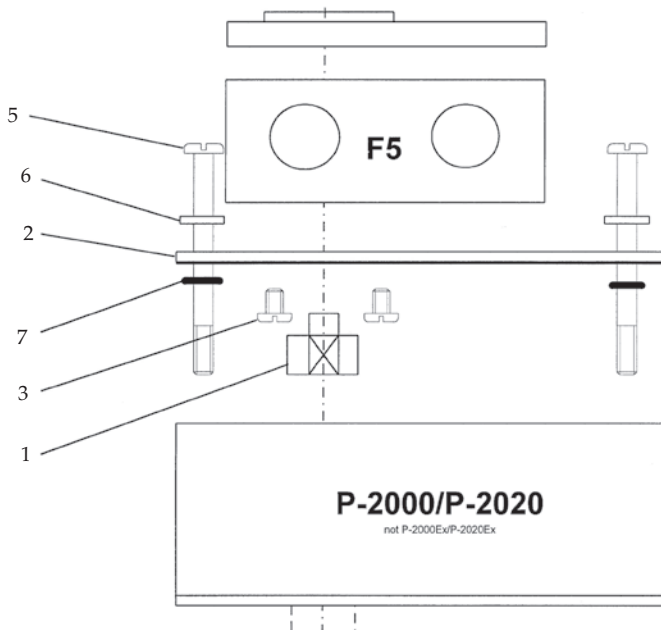



## F5-EX

The F5-EX is approved explosion proof by CSA, FM and ATEX.  
Front cover screws shall be tightened 7 Nm (5,2 lbf x ft).

Approvals:

CSA, FM Div. 1, Class 1,2 & 3 Group BCDEFG T4-T6

ATEX II 2 G EEx d IIB + H2 T4-T6

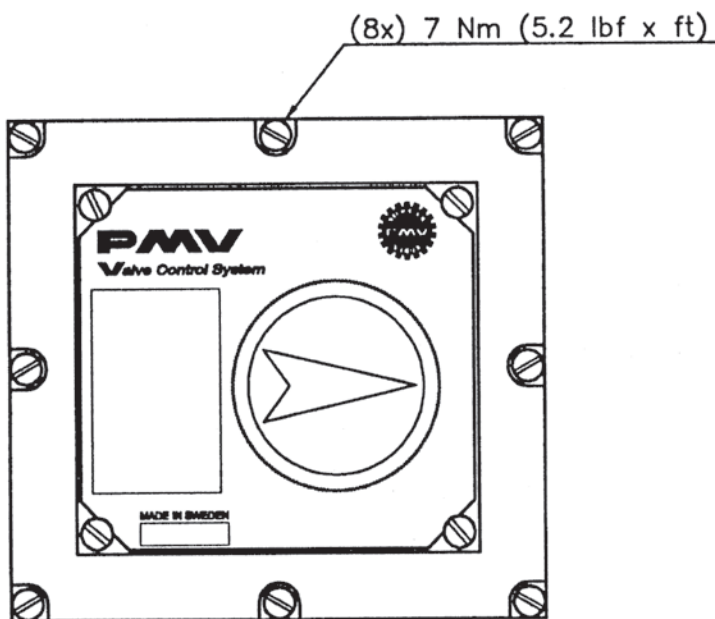

## Installing F5-EX on P5/EP5

- See [www.pmv.nu/downloads](http://www.pmv.nu/downloads) for video clip.
- Remove front cover, indicator and Allen head screw from the positioner.
- Install drive coupling 4 and secure it with the Allen head screw.
- Remove front covers and indicator from the F5-EX unit.
- Remove screws 3.
- Install F5-EX on P5/EP5, make sure drive coupling is properly engaged before tightening screws 5.
- Reinstall and tight screws 3. Connect and calibrate.
- Reinstall front covers and indicator.
- Front cover screws 2 shall be tightened to 7 Nm (5,2 lbf x ft)

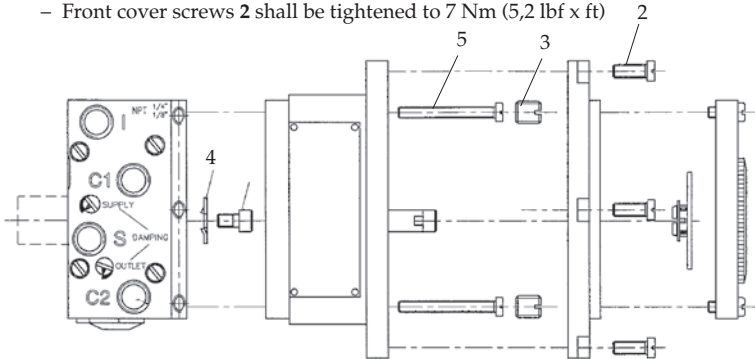

## Installing on an actuator

- Remove front covers and indicator from the F5-EX unit.
- Remove screws 3 and (5). Reinstall and tight screws 3.
- Install drive shaft into F5-EX, a solid click should be heard when spindle adapter is properly installed.
- Mount F5-EX on the actuator using the F05 holes and a mounting kit.
- Connect and calibrate, reinstall front covers and indicator.
- Front cover screws 2 shall be tightened to 7 Nm (5,2 lbf x ft).

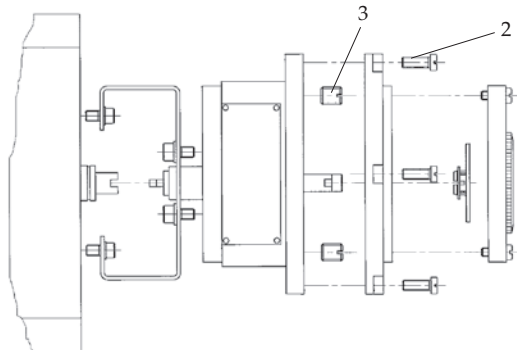

## Connections

### WARNING!

Units installed in hazardous locations must have proper agency approvals and be installed according to installation drawing F5-2-4-9516.

Conduit entries are PG13,5 (M20) or NPT 1/2"

Make electrical connections according to wiring diagrams and tighten cable glands. Terminals are 2.5 mm<sup>2</sup> (AVG 14) screw terminals.

## Adjustments

### CAUTION! Moving parts – risk of injury.

The cams/gear wheel are secured in position by friction provided from the cam/shaft assembly. To adjust switches and/or position transmitter, rotate gear wheel **2** and cams **3** to desired position using tool **F5-22** or tip of a screw driver that fits snugly in one of the slotted holes. Start calibration procedure by adjusting position transmitter first, then continue with the lower switch and complete with the upper switch.

If cams exhibit high stiction, rotate them back and forth rapidly several times. Do not adjust nut **4** or lubricate cams, call PMV for assistance.

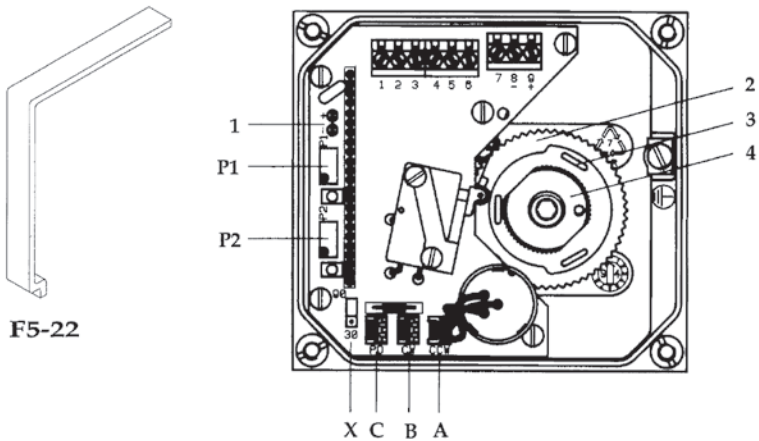

# Calibration

## 4-20 mA position transmitter

Instruction video available on [www.pmv.nu/downloads](http://www.pmv.nu/downloads)

- Set direction of rotation by placing potentiometer jumper in location A or B. (Location **A** for counter clockwise CCW valve/actuator rotation (Direct), location **B** for clockwise CW valve/actuator rotation (Reverse).
- Set jumper X to the desired valve rotation angle, for 30 deg or 45 deg rotation choose position 30,  
For 60 deg or 90 deg rotation choose position 90, for 180 deg rotation choose position 30 and for 270 deg rotations choose position 90.  
For 30° deg - 45° deg choose pos 30.
- Make electrical connections according to wiring diagram. Power supply should be >9 to <28 VDC (24 VDC recommended).
- Connect a 4-20 mA meter to testoutlet 1. Adjust potentiometer **P1** 20 revolutions CW & **P2** 20 revolutions CCW. Stroke actuator to the desired 4 mA position and check that current deflection is correct. Rotate gear wheel 2 with tool **F5-22** or tip of a screw driver placed in one of the slotted holes until minimum value is reached.
- Adjust the output signal 4,0 mA with potentiometer **P2**. LED will illuminate when out put is 4 mA ( $\pm 1\%$ ) or less. Stroke actuator to the desired 20 mA position and adjust the output to 20,0 mA with potentiometer **P1**. LED will illuminate when out put is 20 mA ( $\pm 1\%$ ) or more.
- Stroke actuator again, check and adjust 4 mA and 20 mA readings. Install front cover or set switches first, as follows:

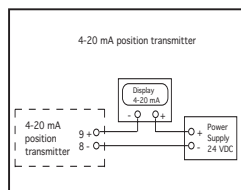

# Switches & Sensors

Limit switches cams must be adjusted separately with valve in an open and closed position. With the valve in fully open or closed position adjust the lower cam 3 to desired position by rotating it with special tool F5-22 or by the tip of a screw driver placed in one of the slotted holes on the cam. Stroke the valve fully and repeat the procedure above to set the upper cam. Stroke valve open/closed to check proper limit switch operation.

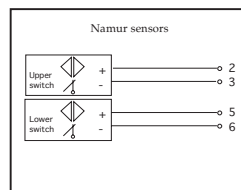
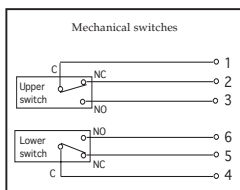
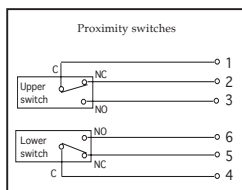

## Potentiometer only (no transmitter function)

1. Make electrical connections to terminals 7,8 and 9. Check that the potentiometer is connected to connector C on the printed circuit board.
2. Stroke the actuator to check direction of travel indicated by the potentiometer. To change direction of travel, swap wires at terminals 7 and 9.
3. Stroke the actuator to the position where the minimum potentiometer resistance is desired.
4. Adjust the potentiometer output reading to approx. 50 Ohm by rotating gear wheel 2 with special tool F5-22 or tip of a screw driver placed in one of the slotted holes.
5. Stroke the actuator to desired maximum resistance position and check reading.
6. Repeat steps 3-5 if necessary to obtain desired resistance change.
7. Set switches or install frontcover.

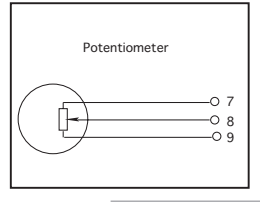

## Technical specifications

### General

Conduit entries	2x 1/2 NPT or 2x PG 13,5 (M20)
Housing material	Die cast aluminum
Surface treatment	ED painting
Mounting	According to VDI/VDE 3845
Fasteners	Stainless steel A2/A4
Terminals	2,5 mm <sup>2</sup> (AVG 14)
Enclosure	IP66, NEMA 4

### Weight

Standard enclosure	0.7 kg (lbs 1.5)
Explosion proof	2.1 kg (lbs 4.6)

### Switches, mechanical

Type	Mechanical SPDT V3
Rating	*6/2,5A 250 VAC *Res/Ind
Approvals	CSA,UL,VDE
Temp range	-40°C to 80°C (-4°F to 185°F)

### Switches proximity

Contact rating	2 W or 2 VA @ 30 VDC/ VAC, 0,1 A
Maximum operating time	0.5 milliseconds
Breakdown voltage	200VDC
Contact resistance	0.2 Ohms
Switch type	SPDT hermetically sealed in one unit

### Sensors, Namur

Type	Proximity DIN 19234 NAMUR
Load Current	≤ 1mA ≥ 3mA
Voltage range	5-25 VDC
Hysteresis	0,2%
Temp range	-20°C to 80°C (-4°F to 185°F)

### Mechanical and electrical life

>10 million operations

### Potentiometer

Out put	5kΩ (4kΩ at 90°)
Elements	Conductive plastic
Power rating at 70°	1 W
Linearity	1%
Resolution	Essentially infinite
Temp range	-40°C to 80°C (-4°F to 185°F)

### 4-20 mA position transmitter

Power supply	9-28 VDC (24VDC recommended)
Out put signal	4-20 mA
LED indication at 4 mA	±1%
LED indication at 20 mA	±1%
Resolution	Infinite
Minimum rotation travel	30°
Maximum rotation travel	90°
Linearity	<1% of full scale
Hysteresis	<0,5% of full scale
Out put current limit	24 mA DC
Load impedance	800 Ω at 24 VDC
Temp range	-40°C to 80°C (-4°F to 185°F)



# Connection of F5 intrinsically safe version

**Hazardous area**

Alt. 1  
Mechanical switches  
Not in combination  
with alt. 2-5

STAHl 9001/01-280-050,085,100-10 ③

**Non hazardous area**  
CSA, FM approved safety barrier

STAHl 9001/01-280-050,085,100-10 ③

Alt. 2  
Mechanical switches

STAHl 9251/02-10,20,40,80

Alt. 3  
Inductive Namur switches

STAHl 9251/02-10,20,40,80

Alt. 4  
Potentiometer

STAHl 9001/01-168-50-10

Alt. 5  
4-20mA transmitter

STAHl 9001/01-280-091-14

③ INSTALLATION INSTRUCTIONS FOR CLASS 1 DIVISION 2 VERSION:

- For CSA install in accordance with the Canadian electrical code, part 1
- To be connected without safety barriers.
- Electrical ratings: See table below.
- WARNING EXPLOSION HAZARD! Do not disconnect the equipment unless power has been switched off, or the area is known to be non-hazardous. Substitution of components may impair suitability for Class 1 Div.2.

F5 TYPE	Connect-	HAZARDOUS APPROVALS	QUADRUPLE EXPL. PROTECT. CLASS DIV. 2	ELECTRICAL RATINGS
F5-SW/MEC	1	10n Alt. 1, CL.I, DIV.1, CL.II, DIV.2	1	Max. 28V, 100mA
F5-SW/MEC	2	A,B,C,D, T6	2	28 100
F5-SW/MEC-420	2 + 5	C,D, T3C	-	-
F5-SW/MEC-POT1	1 + 4	A,B,C,D, T6	-	-
F5-SW/MEC-POT2	2 + 4	A,B,C,D, T6	-	-
F5-SW/NAW	3	A,B,C,D, T6	15,5	32 25 100
F5-SW/NAW-420	3 + 5	C,D, T3C, A,B,C,D, T6	-	-
F5-SW/NAW-POT1	3 + 4	A,B,C,D, T6	-	-
F5-SW/NAW-POT2	3 + 5	A,B,C,D, T6	28	100
F5-420	5	A,B,C,D, T3C, A,B,C,D, T6	28	100 35 100
F5-SW/PXY	1	A,B,C,D, T6	28	100 28 100
F5-SW/PXY-420	2 + 5	A,B,C,D, T6	28	100 28 100

⑦ Connection diagram

DESCRIPTION

UNREGISTERED TRADEMARK ACCORDING TO

REGISTERED TRADEMARK

DATE: 11/2019

MATERIAL

DIMENSION

PROTECTION AREA

ANNOTATION

PMV Feedback unit

F5

Scale: 1:1

DATE: 03/2019

HAUSER/STÄBE

REF. NUMBER

PALMSTIERNA INTERNATIONALE AB

KORTA GATAN 9 SE-171 54 SOLNA SWEDEN - TEL: +46(0)8 555 106 00 - FAX: +46(0)8 555 106 01 - WWW.HAUSER.COM

F5-2-4-9516

# F5 IS



L C I E

<p><b>1 ATTESTATION D'EXAMEN CE DE TYPE</b></p> <p>2 Appareils et systèmes de protection destinés à être utilisés en atmosphères explosibles Directive 94/9/CE</p> <p>3 Numéro de l'attestation CE de type LCIE 03 ATEX 6103 X</p> <p>4 Appareil ou système de protection : Module de contrôle (Feed back unit) Type : F5-SW/MEC, F5-SW/MEC-420, F5-SW/MEC-POT, F5-SW/NAM, F5-SW/NAM-420, F5-SW/NAM-POT, F5-POT, F5-420, F5-SW/PXY, F5-SW/PXY/420 et F5-SW/PXY/POT</p> <p>5 Demandeur : PALMSTIERNAS INSTRUMENTS AB</p> <p>6 Adresse : Korta Gatan 9 SE-171 54 SOLNA SUEDE</p> <p>7 Cet appareil ou système de protection et ses variantes éventuelles acceptées est décrit dans l'annexe de la présente attestation et dans les documents descriptifs cités en annexe.</p> <p>8 Le LCIE, organisme notifié sous la référence 0081 conformément à l'article 9 de la directive 94/9/CE du Parlement européen et du Conseil du 23 mars 1994, certifie que cet appareil ou système de protection est conforme aux exigences essentielles en ce qui concerne la sécurité et la santé pour la conception et la construction d'appareils et de systèmes de protection destinés à être utilisés en atmosphères explosibles, données dans l'annexe II de la directive. Les vérifications et épreuves figurent dans notre rapport confidentiel N° 60006923/501480.</p> <p>9 Le respect des exigences essentielles en ce qui concerne la sécurité et la santé est assuré par la conformité aux documents suivants : -EN 50014 (1997) + amendements 1 et 2 -EN 50020 (1994) et EN 50284 (1999).</p> <p>10 Le signe X lorsqu'il est placé à la suite du numéro de l'attestation, indique que ce matériel ou système de protection est soumis aux conditions spéciales pour une utilisation sûre, mentionnées dans l'annexe de la présente attestation.</p> <p>11 Cette attestation d'examen CE de type concerne uniquement la conception et la construction de l'appareil ou du système de protection spécifié, conformément à la directive 94/9/CE. Des exigences supplémentaires de cette directive sont applicables pour la fabrication et la fourniture de l'appareil ou du système de protection.</p> <p>12 Le marquage de l'appareil ou du système de protection devra comporter, entre autres indications utiles, les mentions suivantes : ⊕ II 1 G EEx ia IIC T4</p> <p>Fontenay-aux-Roses, le 16 avril 2003</p>	<p><b>1 EC TYPE EXAMINATION CERTIFICATE</b></p> <p>2 Equipment or protective system intended for use in potentially explosive atmospheres Directive 94/9/EC</p> <p>3 EC type Examination Certificate number LCIE 03 ATEX 6103 X</p> <p>4 Equipment or protective system : Monitoring unit (Feed back unit) Type : F5-SW/MEC, F5-SW/MEC-420, F5-SW/MEC-POT, F5-SW/NAM, F5-SW/NAM-420, F5-SW/NAM-POT, F5-POT, F5-420, F5-SW/PXY, F5-SW/PXY/420 and F5-SW/PXY/POT</p> <p>5 Applicant : PALMSTIERNAS INSTRUMENTS AB</p> <p>6 Address : Korta Gatan 9 SE-171 54 SOLNA SWEDEN</p> <p>7 This equipment or protective system and any acceptable variation thereto is specified in the schedule to this certificate and the documents therein referred to.</p> <p>8 LCIE, notified body number 0081 in accordance with article 9 of the Directive 94/9/EC of the European Parliament and Council of 23 March 1994, certifies that this equipment or protective system has been found to comply with the essential Health and Safety Requirements relating to the design and construction of equipment and protective system intended for use in potentially explosive atmospheres, given in Annex II of the Directive. The examination and test results are recorded in confidential report No 60006923/501480.</p> <p>9 Compliance with the Essential Health and Safety Requirements has been assured by compliance with : -EN 50014 (1997) + amendments 1 and 2 -EN 50020 (1994) and EN 50284 (1999).</p> <p>10 If the sign X is placed after the certificate number, it indicates that the equipment or protective system is subject to special conditions for safe use specified in the schedule to this certificate.</p> <p>11 This EC Type examination certificate relates only to the design and construction of this specified equipment or protective system in accordance with the Directive 94/9/EC. Further requirements of the Directive apply to the manufacture and supply of this equipment or protective system.</p> <p>12 The marking of the equipment or protective system shall include the following : ⊕ II 1 G EEx ia IIC T4</p> <p>Le Directeur de l'organisme certificateur Manager of the certification body</p>
--	--

*Isabelle HELLER*  
Isabelle HELLER  
Timbre sec / Dry seal

Seul le texte en français peut engager la responsabilité du LCIE. Ce document ne peut être reproduit que dans son intégralité, sans aucune modification.  
The LCIE's liability applies only on the French text. This document may be reproduced in full and without any change

Page 1/3

LCIE	33, av du Général Leclerc	TEL : +33 1 40 95 60 60	Société anonyme à direction et conseil de surveillance
Laboratoire Central	BP 8	Fax : +33 1 40 95 86 56	au capital de 15 745 081 €
dcs Industries Electriques	92206 Fontenay-aux-Roses cedex	contact@lci.fr	RCS Nanterre B 408 365 174
Une société de Bureau Veritas	France	www.lci.fr	

# F5 IS



(A1) ANNEXE

(A1) SCHEDULE

(A2) ATTESTATION D'EXAMEN CE DE TYPE

(A2) EC TYPE EXAMINATION CERTIFICATE

LCIE 03 ATEX 6103 X

LCIE 03 ATEX 6103 X

(A3) Description de l'équipement ou du système de protection :  
Module de contrôle (Feed back unit)

Type : F5-SW/MEC, F5-SW/MEC-420, F5-SW/MEC-POT,  
F5-SW/NAM, F5-SW/NAM-420, F5-SW/NAM-POT, F5-POT,  
F5-420, F5-SW/PXY, F5-SW/PXY420 et F5-SW/PXY/POT

Le module de contrôle détecte la position et le sens de déplacement d'un disque ou d'un arbre.

Selon les capteurs montés, il peut exister onze modèles. Certains modèles comportent un transmetteur 4-20 mA.

Les capteurs inductifs, certifiés de sécurité intrinsèque, raccordés aux bornes 2-3 et 5-6 peuvent être de type :

- PEPPERL & FUCHS, type NJ2-V3-N,
  - Ou IFM ELECTRONICS, type NS 5002,
- Ou équivalent.

Le marquage est le suivant :

PALMSTIERNAS ou PMV  
Adresse : ...  
Type : F5\*\*\*\* (1)  
N° de fabrication : ...  
Année de construction : ...  
II 1 G  
EEx ia IIC T4  
LCIE 03 ATEX 6103 X

(1) selon les variantes définies ci-dessus.

Le marquage CE est accompagné du numéro d'identification de l'organisme notifié responsable de la surveillance du système approuvé de qualité (0081 pour le LCIE).

Le matériel devra également comporter le marquage normalement prévu par les normes de construction du matériel électrique concerné

Paramètres spécifiques du ou des modes de protection concerné(s) :

- \* Transmetteur 4-20 mA – Bornes 8-9 :  
Ui = 28 V, Ii = 100 mA, Li = 0 et Ci = 68 nF.
- \* Capteurs inductifs – Bornes 2-3 et 5-6 :  
Ui = 15,5 V, Ii = 31 mA, Li = 190 µH et Ci = 70 nF.
- \* Potentiomètre – Bornes 7-8-9 :  
Ui = 28 V, Pi = 0,85 W.

(A4) Documents descriptifs :

Dossier technique N° F5\_24.DOC/01 Rev 0 en date du 25 février 2003.  
Ce document comprend 33 rubriques (35 pages).

(A3) Description of Equipment or Protective System:  
Monitoring unit (Feed back unit)

Type : F5-SW/MEC, F5-SW/MEC-420, F5-SW/MEC-POT,  
F5-SW/NAM, F5-SW/NAM-420, F5-SW/NAM-POT, F5-POT,  
F5-420, F5-SW/PXY, F5-SW/PXY420 and F5-SW/PXY/POT

The monitoring unit detects the position and the direction of displacement of a disk or a shaft.

According to the integrated sensors, there are eleven models. Some of the models include a 4-20 mA transmitter.

The inductive sensors, intrinsically safe certified, connected to terminals 2-3 and 5-6 could be as following :

- PEPPERL & FUCHS, type NJ2-V3-N,
  - Ou IFM ELECTRONICS, type NS 5002,
- Or equivalent.

The marking is the following :

PALMSTIERNAS or PMV  
Address : ...  
Type : F5\*\*\*\* (1)  
Serial number : ...  
Year of construction : ...  
II 1 G  
EEx ia IIC T4  
LCIE 03 ATEX 6103 X

(1) according to the variations as described below.

The CE marking shall be accompanied by the identification number of the notified body responsible for surveillance of the approved quality system (0081 for LCIE).

The equipment must also carry the usual marking required by the manufacturing standards applying to such equipments.

Specific parameters of the mode of protection concerned :

- \* 4-20 mA transmitter – Terminals 8-9 :  
Ui = 28 V, Ii = 100 mA, Li = 0 and Ci = 68 nF.
- \* Inductive sensors – Terminals 2-3 and 5-6 :  
Ui = 15,5 V, Ii = 31 mA, Li = 190 µH and Ci = 70 nF.
- \* Potentiometer – Terminals 7-8-9 :  
Ui = 28 V, Pi = 0,85 W.

(A4) Descriptive documents :

Technical file No F5\_24.DOC/01 Rev 0 dated February 25th, 2003.  
This file includes 33 items (35 pages).





# F5 IS



L C E

(A1) ANNEXE

(A1) SCHEDULE

(A2) ATTESTATION D'EXAMEN CE DE TYPE

(A2) EC TYPE EXAMINATION CERTIFICATE

LCIE 03 ATEX 6103 X

LCIE 03 ATEX 6103 X

(A5) Conditions spéciales pour une utilisation sûre :

Les différents circuits du matériel ne devront être raccordés qu'à des matériels certifiés de sécurité intrinsèque ou matériels associés de sécurité intrinsèque, et ces associations devront être compatibles avec les règles de la sécurité intrinsèque.

Les différents circuits peuvent être considérés comme séparés si aucune des tensions appliquées ne dépasse 30 V.

(A6) Exigences essentielles en ce qui concerne la sécurité et la santé :

Conformité aux normes européennes EN 50014 (1997 + amendements 1 et 2), EN 50020 (1994) et EN 50284 (1999).

Vérifications et épreuves individuelles  
Néant.

(A5) Special conditions for safe use:

The various circuits of the electrical apparatus must only be connected to intrinsically safe certified electrical apparatus or to intrinsically safe accessories, and these combinations must be compatible with the rules of intrinsic safety.

The various circuits may be considered as separated if none of the voltages applied exceeds 30 V.

(A6) Essential Health and Safety Requirements:

Conformity to the European standards EN 50014 (1997 + amendments 1 and 2), EN 50020 (1994) and EN 50284 (1999).

Individual examinations and tests  
None.



## Certificate of Compliance

Certificate Number: LR 69005-12

Revision: PALMSTERNAS INSTRUMENTS AB  
 Tulegatan 15, 3 fr.  
 Stockholm S-113 53,  
 Sweden

Date Issued: July 3, 1997

Attention: Mr. Mats Ragnarsson

*The products listed below are eligible to bear the CSA Mark*

Issued by: Y. Kishino, P. Eng  
 Toronto, ON Canada

Signature:

CLASS 2286 02 - PROCESS CONTROL EQUIPMENT - For Hazardous Locations

### PRODUCTS

Class I, Groups B, C, and D, Class II, Groups E, F and G, Class III

- Modif F5EX Series feedback units, rated 28V dc max; Modif F5EX-MEC, -MEC/POT, -MEC/420, -NAM, -NAM/POT, -NAM/420, -POT and -420, enclosure Type 4X, Temperature Code T6 (amb. +50C max), T5 (amb. +80C)

### APPLICABLE STANDARDS

- CSA Std C22.2 No. 24-1066 - Endusers for Use in Class II, Groups E, F and G Hazardous Locations
- CSA Std C22.2 No. 30-M1096 - Endusers for Use in Class I Hazardous Locations
- CAN/CSA-C22.2 No. 04-M101 - Special Purpose Endusers
- CSA Std C22.2 No. 142-M1987 - Process Control Equipment

DPO 517

Canadian Standards Association Office, Montreal, Toronto, Vancouver, Winnipeg, Hong Kong



### 1 ATTESTATION D'EXAMEN CE DE TYPE

- 1 Apprécier et systèmes de protection destinés à être utilisés en atmosphères explosives
- 2 Apprécier et systèmes de protection destinés à être utilisés en atmosphères explosives
- 3 Numéro de attestation: CE de type
- 4 L'CE 03 ATEX 6137
- 5 Appareil ou système de protection: Equipement de protection Type: F5EX - ...
- 6 Demandaeur: PALMSTERNAS INSTRUMENTS AB
- 7 Adresse: Kungälv 9, SE-711 54 SOLNA, SUÈDE
- 8 L'CE 03 ATEX 6137 a été vérifiée par les autorités compétentes accréditées en vertu de la norme de la présente attestation et dans les documents décrits ci-dessous
- 9 L'CE 03 ATEX 6137 a été vérifiée par les autorités compétentes accréditées en vertu de la norme de la présente attestation et dans les documents décrits ci-dessous
- 10 Le signe X (encadré) est placé à la suite du numéro de protection, lorsque que les conditions ou les procédures de production sont conformes au système de production, mentionnés dans l'annexe de la présente attestation.
- 11 Le document d'examen CE de type concerne notamment la conception et la construction de l'appareil ou du système de protection spécifiés, conformément à la directive 94/9/CE, applicable pour la fabrication et la fourniture de l'appareil ou du système de protection.
- 12 Le prototype de l'appareil ou du système de protection décrits ci-dessus a été soumis à l'examen CE de type.

Fortitrygningsselskabet, la 20 mai 2003

### 1 EC TYPE EXAMINATION CERTIFICATE

- 1 Equipment or protective system intended for use in potentially explosive atmospheres
- 2 Equipment or protective system intended for use in potentially explosive atmospheres
- 3 EC type Examination Certificate number: LCE 03 ATEX 6137
- 4 Equipment or protective system: Equipment of protection Type: F5EX - ...
- 5 Applicant: PALMSTERNAS INSTRUMENTS AB
- 6 Address: Kungälv 9, SE-711 54 SOLNA, SWEDEN
- 7 The certificate of protection system and any applicable provisions have been verified in accordance with the standards and the documents therein referred to.
- 8 LCE 03 ATEX 6137 has been verified in accordance with article 9 of the Directive 94/9/EC of the European Parliament and Council of 23 March 1994, certifies that the equipment or system is in conformity with the essential health and safety requirements relating to the design and construction of equipment and protective system in Annex II of the Directive.
- 9 The examination and test results are recorded in confidential Certificate No. 030001 0052 1997.
- 10 The sign X (boxed) is placed after the certificate number, it indicates that the equipment or protective system is subject to special conditions for use specified in the certificate in this certificate.
- 11 The EC type examination certificate shall be the design and construction of this specific equipment or protective system in accordance with the Directive 94/9/EC, applicable for the manufacture and supply of the equipment of protective system.
- 12 The marking of the equipment or protective system shall include the following:

Le Directeur de l'organisme certificateur  
 Manager of the certification body

H. NERVELLO  
 Imprimeur: DTY s.a.s.

Send in book or brochure and request is responsible to the CE. Ce document est posté dans votre dossier personnel. Veuillez retourner le document à l'organisme certificateur. The CE's quality system is for the French text. This document may be reproduced in full or in part without any charge.

# F5-EX

C E T E		SCHEDULE
<p>(A1) ANNEXE</p> <p>(A2) ATTESTATION D'EXAMEN CE DE TYPE</p> <p>LCIE 03 ATEX 6137</p> <p>Modèle Type : F5EX... intégrant</p> <p>(A3) Description de l'équipement ou du système de protection :</p> <p>Modèle Type : F5EX... intégrant</p>	<p>(A2) EC TYPE EXAMINATION CERTIFICATE</p> <p>LCIE 03 ATEX 6137</p> <p>The equipment mounted on top of a valve positioner gives information about positioning via mechanical or inductive switches and/or rolling angle via potentiometer or current transmitter.</p> <p>The marking is the following:</p> <p><b>PALMSTERMAS</b></p> <p>Type F5EX... (1)</p> <p>IEC d IIB, II G</p> <p>Ex d IIB, II G, T4 ou T5 ou T4</p> <p>15 pour 1 amb = + 80°C</p> <p>15 pour 1 amb = + 80°C</p> <p>LCIE 03 ATEX 6137</p> <p>NE PAS OUVRIR SANS TENSION</p> <p>(1) selon les variantes définies dans la notice descriptive du</p> <p>Le marquage CE est accompagné du numéro d'identification de l'appareil modèle responsable de la surveillance du système approuvé de qualité (0081 pour la LCIE).</p> <p>Le matériel devra également comporter le marquage électrique convenu</p> <p>Caractéristiques, désignations, du ou des modèles de construction (G)</p> <p>Tension maximale : 28 V C.C.</p> <p>Courant maximal : 1,20 mA.</p> <p>Puissance maximale : 1,20 mW.</p> <p>(A4) Documents descriptifs :</p> <p>Dossier technique N° F5X-00225 (0 Row 0 en date du 25 février Ce document comprend 30 rubriques (32 pages)</p> <p>(A5) Conditions spéciales pour une utilisation sûre :</p> <p>NONE</p> <p>(A6) Exigences essentielles en ce qui concerne la sécurité et la santé :</p> <p>Conformité aux normes européennes EN 50014 (1987 + Amendements 1 et 2) et EN 50019 (2005).</p> <p>Vérifications et essais réalisés</p> <p>Modèle F5EX... (1) (2) (3) (4) (5) (6) (7) (8) (9) (10) (11) (12) (13) (14) (15) (16) (17) (18) (19) (20) (21) (22) (23) (24) (25) (26) (27) (28) (29) (30) (31) (32) (33) (34) (35) (36) (37) (38) (39) (40) (41) (42) (43) (44) (45) (46) (47) (48) (49) (50) (51) (52) (53) (54) (55) (56) (57) (58) (59) (60) (61) (62) (63) (64) (65) (66) (67) (68) (69) (70) (71) (72) (73) (74) (75) (76) (77) (78) (79) (80) (81) (82) (83) (84) (85) (86) (87) (88) (89) (90) (91) (92) (93) (94) (95) (96) (97) (98) (99) (100)</p> <p>Page 2/2</p>	<p>(A3) Description of Equipment or Protective System</p> <p>Modèle Type : F5EX... intégrant</p> <p>The equipment mounted on top of a valve positioner gives information about positioning via mechanical or inductive switches and/or rolling angle via potentiometer or current transmitter.</p> <p>The marking is the following:</p> <p><b>PALMSTERMAS</b></p> <p>Type F5EX... (1)</p> <p>IEC d IIB, II G</p> <p>Ex d IIB, II G, T4 ou T5 ou T4</p> <p>15 for 1 amb = + 80°C</p> <p>15 for 1 amb = + 80°C</p> <p>LCIE 03 ATEX 6137</p> <p>DO NOT OPEN WHILE ENERGIZED</p> <p>(1) according to the variations as described by the manufacturer's</p> <p>The CE marking shall be accompanied by the identification number of the notified body responsible for surveillance of the approved quality system (0081 for LCIE).</p> <p>The equipment must also carry the usual marking required by the manufacturing standards applying to such equipments.</p> <p>The marking shall also carry the usual marking required by the manufacturing standards applying to such equipments.</p> <p>Specific parameters of the model or models concerned:</p> <p>Maximum voltage : 28 V C.C.</p> <p>Maximum current : 0,20 mA.</p> <p>Maximum power : 1,20 mW.</p> <p>(A4) Descriptive documents :</p> <p>Technical file No F5X-00225 (0 Row 0 dated February 25th, This file includes 30 items (32 pages).</p> <p>(A5) Special conditions for safe use</p> <p>NONE</p> <p>(A6) Essential Health and Safety Requirements</p> <p>Conformity to the European standards EN 50014 (1987 + Amendments 1 and 2) et EN 50019 (2005).</p> <p>Individual examination and tests</p> <p>None</p> <p>Fig 1-11 1-12 1-13 1-14 1-15 1-16 1-17 1-18 1-19 1-20 1-21 1-22 1-23 1-24 1-25 1-26 1-27 1-28 1-29 1-30 1-31 1-32 1-33 1-34 1-35 1-36 1-37 1-38 1-39 1-40 1-41 1-42 1-43 1-44 1-45 1-46 1-47 1-48 1-49 1-50 1-51 1-52 1-53 1-54 1-55 1-56 1-57 1-58 1-59 1-60 1-61 1-62 1-63 1-64 1-65 1-66 1-67 1-68 1-69 1-70 1-71 1-72 1-73 1-74 1-75 1-76 1-77 1-78 1-79 1-80 1-81 1-82 1-83 1-84 1-85 1-86 1-87 1-88 1-89 1-90 1-91 1-92 1-93 1-94 1-95 1-96 1-97 1-98 1-99 1-100</p>

**F**ACTORY MUTUAL |   
 Factory Mutual Research Corporation  
 151 Boston-Providence Turnpike  
 P.O. Box 9102  
 Norwood, Massachusetts 02062

J.L. IRISNA AE (3615) October 14, 1997

**SERIES F5EX FEEDBACK UNIT FOR HAZARDOUS (CLASSIFIED) LOCATIONS**

**PALMSTERMAS INSTRUMENT AB**  
 from  
 TULÉGATAN 15  
 S-113 85 STOCKHOLM  
 SWEDEN

## I INTRODUCTION

1.1 Palmstermas Instrument AB (manufacturer) requested Factory Mutual Research Corporation (FMRC) Approval of their Series F5EX Feedback Unit as explosionproof for Class I, Division 1, Groups B, C and D; dust-ignitionproof for Class II, Division 1, Groups E, F and G hazardous (classified) locations, indoors and outdoors (NEMA Type 4X). Canadian Standards Association (CSA) performed the examination and testing for possible FMRC Approval based on the Inter-laboratory agreement between FMRC and CSA.

1.2 The Listing in the FMRC Approval Guide for the Series F5EX Feedback Unit will appear in the FMRC Approval Guide as follows:

**XP/II/L/IBCD; DIP/II/L/IEEG**

Feedback Unit: Modèle F5EX-MEC, F5EX-MEC/20, F5EX-MEC/POT, F5EX-NAM, F5EX-NAM/20, F5EX-NAM/POT, F5EX-POT and F5EX-420.

# Spare Parts

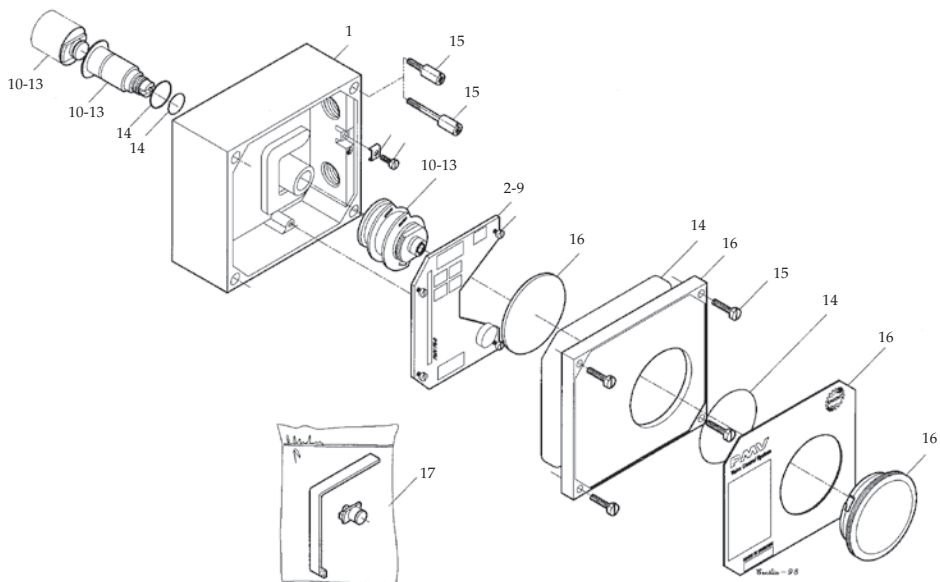

## Spare Parts List

DWG No	PMV Part no	Description	Qty	Set
1		Housing		
2	28176	PC board incl. 2 x Mechanical switches	1	
3	28177	PC board incl. 2 x Mechanical switches and potentiometer	1	
4	28178	PC board incl. 2 x Mechanical switches and 4-20 mA transmitter	1	
5	28179	PC board incl. 2 x Namur sensors	1	
6	28181	PC board incl. 2 x Namur sensors and 4-20 mA transmitter	1	
7	29272	PC board incl. 2 x Proximity switches	1	
8	29270	PC board incl. 2 x Proximity switches and potentiometer	1	
9	29271	PC board incl. 2 x Proximity switches and 4-20 mA transmitter	1	
10	29227	Cam & shaft assy for Mechanical switches or Namur sensors	1	
11	29275	Cam & shaft assy for Proximity switches	1	
12	29228	Cam & shaft assy for Mechanical switches or Namur sensors + transmitter	1	
13	29276	Cam & shaft assy for Proximity switches + transmitter	1	
14	F5-SEAL-NBR	Elastomer kit, Nitrile NBR		1
15	F5-SCREWS	Screw kit F5		1
16	F5-AS2-PV90	Front cover assembly incl. flat indicator		1
17	F5-SP22	Coupling F5-S00 and Adjusting Tool F5-22		1





## Trouble shooting

### Switches

Check electrical connections and cam settings.

### Potentiometer

If there is no output signal, check electrical connections and for open circuit, check that potentiometer is not out of its mechanical range.

If output deflection is wrong reverse connection terminals 7 and 9.

### 4-20 mA position transmitter

If there is no output signal, check electrical connections, polarity, loop power supply, and that the potentiometer is within its range.

If full output signal cannot be achieved by adjustment, check supply voltage and jumper X settings.

If output signal increases and decreases in the wrong direction, move connector from **A** to **B** or vice versa.

If the 4 mA fine adjustment **P2** does not have enough span, zero must be mechanically realigned as follows: Turn **P2** 20 revolutions counter clockwise, then repeat the transmitter calibration procedure.

**Palmstierna International AB**  
Korta Gatan 9  
SE-171 54 Solna  
SWEDEN  
Tel: +46 (0) 8 555 106 00  
Fax: +46 (0) 8 555 106 01  
E-mail: [infopmv@flowserve.com](mailto:infopmv@flowserve.com)  
Internet: [www.pmv.nu](http://www.pmv.nu)

#### SUBSIDIARIES:

##### Flowserve

Abex Road  
Newbury  
Berkshire RG14 5E4  
UK  
Tel: +44 (0) 1635 49 400  
Fax: +44 (0) 1635 36 034  
E-mail: [pmvuk@flowserve.com](mailto:pmvuk@flowserve.com)

##### PMV-USA, Inc

1440 Lake Front Circle  
Unit 160  
The Woodlands, Texas 77380  
USA  
Tel: +1 281 292 7500  
Fax: +1 281 292 7760  
E-mail: [pmvusa@flowserve.com](mailto:pmvusa@flowserve.com)

##### Flowserve

Postfach 2310  
Sperberweg 16  
41468 NEUSS  
GERMANY  
Tel: +49 (0) 2131 795 74 80  
Fax: +49 (0) 2131 795 74 99  
E-mail: [pmvgermany@flowserve.com](mailto:pmvgermany@flowserve.com)

(The information in this brochure is subject to change without notice.)

*Distributor*