



Qualität von Anfang an.

## Teknisk data

### DESIGN

2 delad, gängad kulventil. Handspak med låsning eller vred. Märkt enligt AD-godkännande A4.

### FUNKTION

90° preglering genom handspak eller vred.

### ANSLUTNING

Invändig gänga: 1/4" ... 3"  
Invändig-/ utvändig gänga: 1/4" ... 2"  
Gängning enligt DIN 2999

### TRYCKOMRÅDE

Visst undertryck upp till nominellt tryck PN40 ... PN64. För temperaturer över 80°C se tryck- temperaturdiagram.

### TEMPERATUROMRÅDE

-30°C ... +180°C

### MEDIA

Neutrala gaser och vätskor.

### MATERIAL

Hus: Rostfritt stål 1.4408  
Kula: Rostfritt stål 1.4401  
Tätning: PTFE  
Spindeltätning: PTFE  
Handspak: Rostfritt stål 1.4301  
plastklätt

Ovanstående information är endast avsedd som vägledning och företaget förbehåller sig rätten att ändra data utan föregående meddelande!

## Specification

### DESIGN

2-piece screwed design.  
Hand lever with locking device or butterfly handle. Stamped according to AD-approval A4.

### OPERATION

Rotation through 90° of the hand lever respectively of the butterflyhandle.

### CONNECTION

Female thread: 1/4" ... 3"  
Female-/ male thread: 1/4" ... 2"  
Threads acc. to DIN 2999.

### PRESSURE RANGE

Low vacuum up to nominal pressure PN40 ... PN64. For temperatures over +80°C please refer to the Pressure- Temperature-Diagram.

### TEMPERATURE RANGE

-30°C ... +180°C

### MEDIA

Neutral gases, liquids media.

### MATERIALS

Body: Stainless steel 1.4408  
Ball: Stainless steel 1.4401  
Ball seal: PTFE  
Stem seal: PTFE  
Handle: Stainless steel 1.4301  
plastic coated

The above information is intended for guidance only and the company reserves the right to change any data herein without prior notice!

Artikel:  
**ZL**

2 delad kulventil  
PN40 ... PN64

Rostfritt stål



Type:  
**ZL**

2-way Ball valve  
PN40 ... PN64

Stainless steel



## Förklaring artikelnummer: T.ex. ZL311023 =

2 delad kulventil, rostfritt stål, handspak, invändig gänga 1/2"

Siffror 1. + 2. Produkt	Siffror 3. + 4. Material Hus / Tätning / Kula	Siffror 5. Manöver/reglering	Siffror 6. Alternativ	Siffror 7. + 8. Anslutning
ZL = 2 delad kulventil	31 = Rostfritt stål/ PTFE / rostfritt stål	1 = Handspak 2 = Vred	0 = Invändig gänga 3 = Invändig/utvändig gänga	Gänga (DIN2999) 21 = 1/4 22 = 3/8 23 = 1/2 24 = 3/4 25 = 1 26 = 1 1/4 27 = 1 1/2 28 = 2 29 = 2 1/2 30 = 3  NPT Gänga 51 = 1/4" 52 = 3/8" 53 = 1/2" 54 = 3/4" 55 = 1"

## Ordering example: e.g. ZL311023 =

2-way Ball valve, Stainless steel, Handle, female-/female thread 1/2"

1. + 2. Digit Product	3. + 4. Digit Materials Body / seals / ball	5. Digit Operation	6. Digit Options	7. + 8. Digit Connection
ZL = 2-way Ball valve	31 = Stainless steel / PTFE / Stainless steel	1 = lever handle 2 = butterfly handle	0 = female-/female thread 3 = female-/male thread	Threaded connection (DIN2999) 21 = 1/4 22 = 3/8 23 = 1/2 24 = 3/4 25 = 1 26 = 1 1/4 27 = 1 1/2 28 = 2 29 = 2 1/2 30 = 3  NPT threaded connection 51 = 1/4" 52 = 3/8" 53 = 1/2" 54 = 3/4" 55 = 1"

## Tryck - Temperatur - Diagram / Pressure - Temperature - Diagram

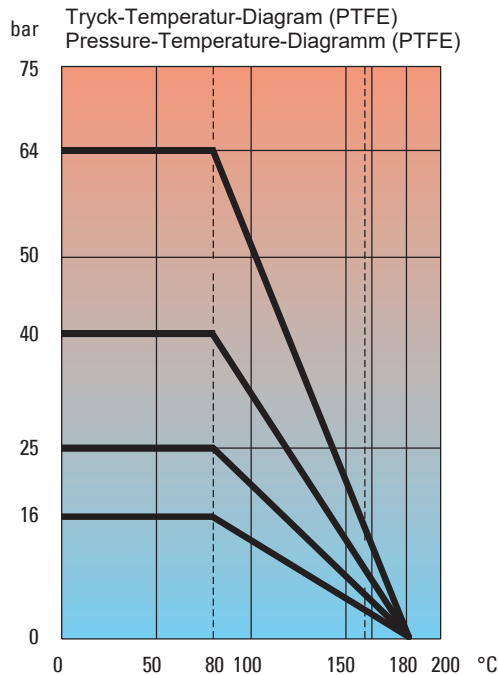

### Information

Produkterna som beskrivs i denna dokumentation är i den form de levereras inga maskiner enligt bilaga 2 punkt a och inga delvis färdigställda maskiner enligt bilaga 2 punkt g i maskindirektivet 2006/42/EG.

### Advice

The products described in this documentation in the conditions of their delivery are no machinery according to annex 2 paragraph a respectively no partly completed machinery according to annex 2 paragraph g of the directive 2006/42/EC on machinery.



# Sprängskiss / Parts list

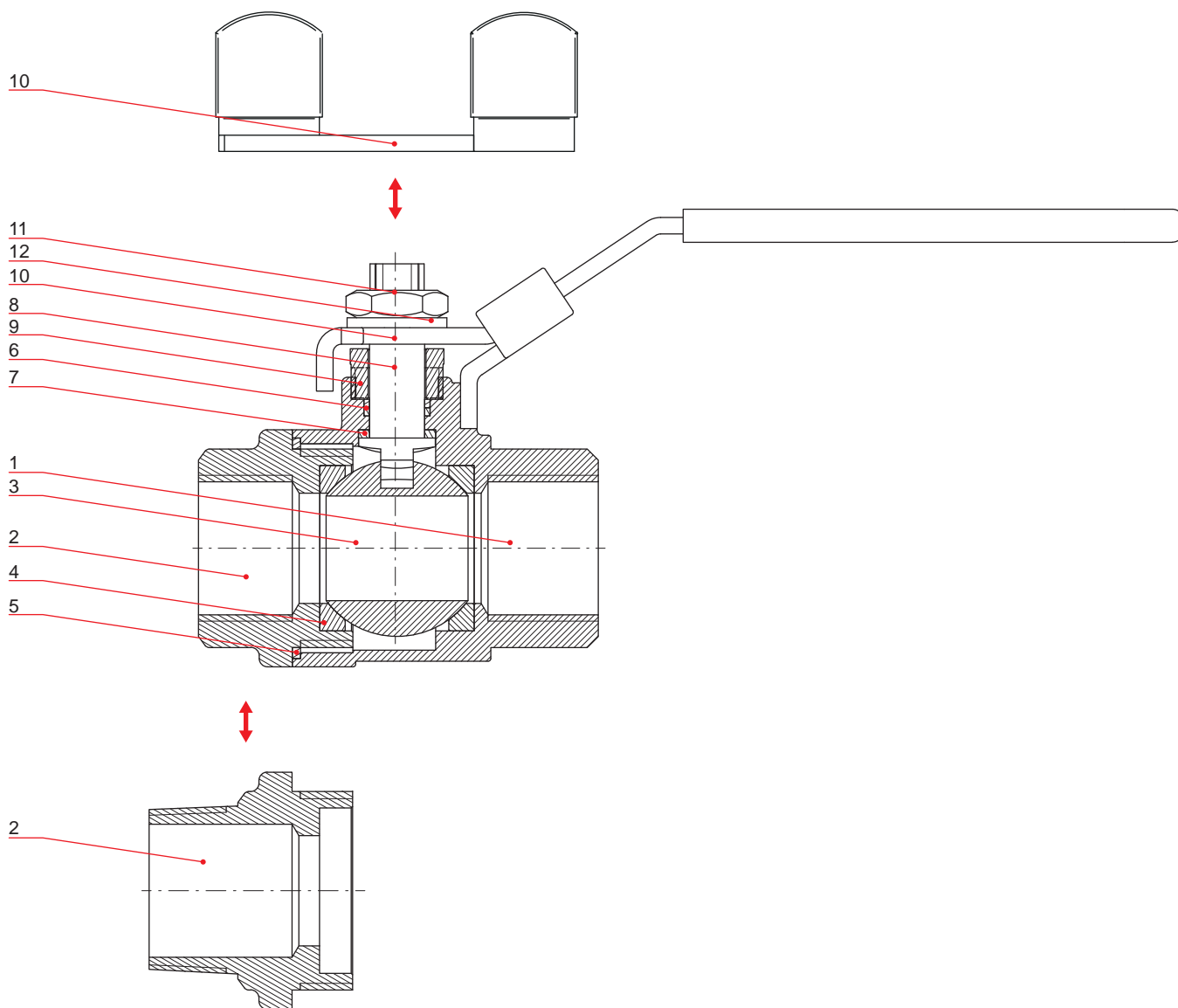

Pos.	Benämning	Description	Material	Material
1	Hus	Body	Rostfritt stål 1.4408	Stainless steel CF8M
2	Anslutning • Invändig gänga • Utvändig gänga	Connection end • female thread • male thread	Rostfritt stål 1.4408	Stainless steel CF8M
3	Kula	Ball	Rostfritt stål 1.4401	Stainless steel 316
4	Kultätning	Ball seal	PTFE	PTFE
5	Tätning hus	Body seal	PTFE	PTFE
6	Spindel­tätning	Stem seal	PTFE	PTFE
7	Tryckbricka	Thrust washer	PTFE	PTFE
8	Spindel	Stem	Rostfritt stål 1.4401	Stainless steel 316
9	Glandmutter	Packing nut	Rostfritt stål 1.4401	Stainless steel 316
10	Handspak • Spak med låsning • Vred	Handle • Lever handle with locking device • Butterfly handle		
11	Mutter	Stem nut	Rostfritt stål 1.4301	Stainless steel 304
12	Fjäderbricka	Spring washer	Rostfritt stål 1.4301	Stainless steel 304

Dok.-Nr.: KAT-ZL-3/4 29.06.2016 - Ändring: Kugelbohrung bei 3" geändert



## Dimensioner / Dimensions

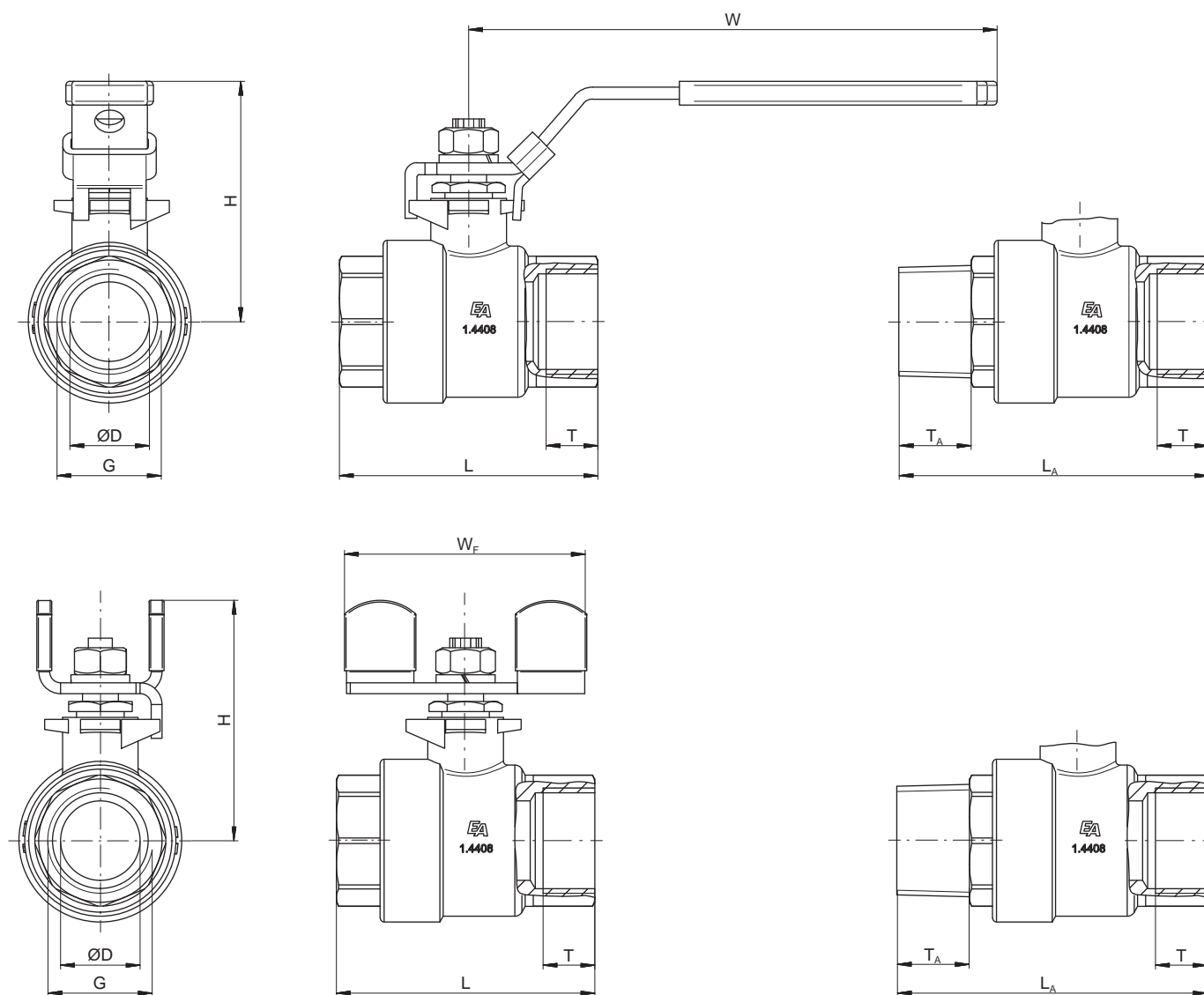

G [ " ]	ØD [mm]	L [mm]	L <sub>A</sub> [mm]	T [mm]	T <sub>A</sub> [mm]	H [mm]	W [mm]	W <sub>F</sub> [mm]	PN [bar]	m [kg]
¼"	11,6	47	57	10,5	11,5	48	101,5	45	64	0,18
⅜"	11,6	48	58	10,5	12	48	101,5	45	64	0,19
½"	15,0	58	70,5	13,5	15,5	52	101,5	50	64	0,26
¾"	20,0	66	78	13,0	17	61	124	60	64	0,40
1"	25,0	77	91	15,5	19	65	124	60	64	0,59
1¼"	32,0	90	105,5	17,5	21,5	79	152	-	40	1,10
1½"	38,0	98	114,5	18,0	21,5	83	152	-	40	1,35
2"	50,0	121	139,5	22,5	25,5	97	190	-	40	2,50
2½"	65,0	145	-	25,5	-	135	242	-	40	4,80
3"	76,0	166	-	28,5	-	144	242	-	40	7,45

Svensk översättning 230112 - AVK Sverige AB/INDVA

Art. ZL - Sida 4/4



END-Armaturen GmbH & Co. KG

Postfach (PLZ 32503) 100 341 · Oberbecksenner Str. 78 · D-32547 Bad Oeynhausen · Telefon (05731) 7900-0 · Telefax (05731) 7900-199 · <http://www.end.de>

Dok.-Nr.: KAT-ZL-4/4 29.06.2016 - Änderung: Kugelbohrung bei 3" geändert