



AVK NOZZLE CHECK VALVE, SINGLE STEM, PN10/16

876/00-001

SS 420 stem, SS 304 spring, alu-bronze bushings, A2 fasteners, FBE coating, EPDM rubber

The AVK spring loaded nozzle check valve is a reliable, fast reacting blocker of reverse flow in water pipes. In case of pump stop the spring loaded valve cone will make sure the water flow is shut off swiftly and quietly before it can change direction and cause water hammer. All metal parts are made of either stainless steel or epoxy coated ductile iron.

Product description:

Fast reacting nozzle check valve with spring return, for drinking water and other neutral liquids to 80°C

Standards:

- Designed according to EN 1074 - 3, Designed according to EN 12266
- Face-to-face dimension according EN 558 - Series 14
- Standard flange drilling to EN1092-2 (ISO 7005-2), PN10/16

Test/Approvals:

Tested to EN12266

- WRAS approved materials

Features:

- A spring loaded valve cone makes sure the valve closes before reverse flow can occur
- The optimized flow path keeps head loss down to a minimum
- Stem, spring and fasteners in stainless steel
- All iron parts coated with 250µm fusion bonded epoxy (FBE)
- Centring stem runs in high strength alu-bronze bushings
- Approved for drinking water according to Decreto Ministeriale nr. 174 - Ministero della Salute



Expect... **AVK**

The designs, materials and specifications shown are subject to change without notice. This is due to the continuous development of our product programme.

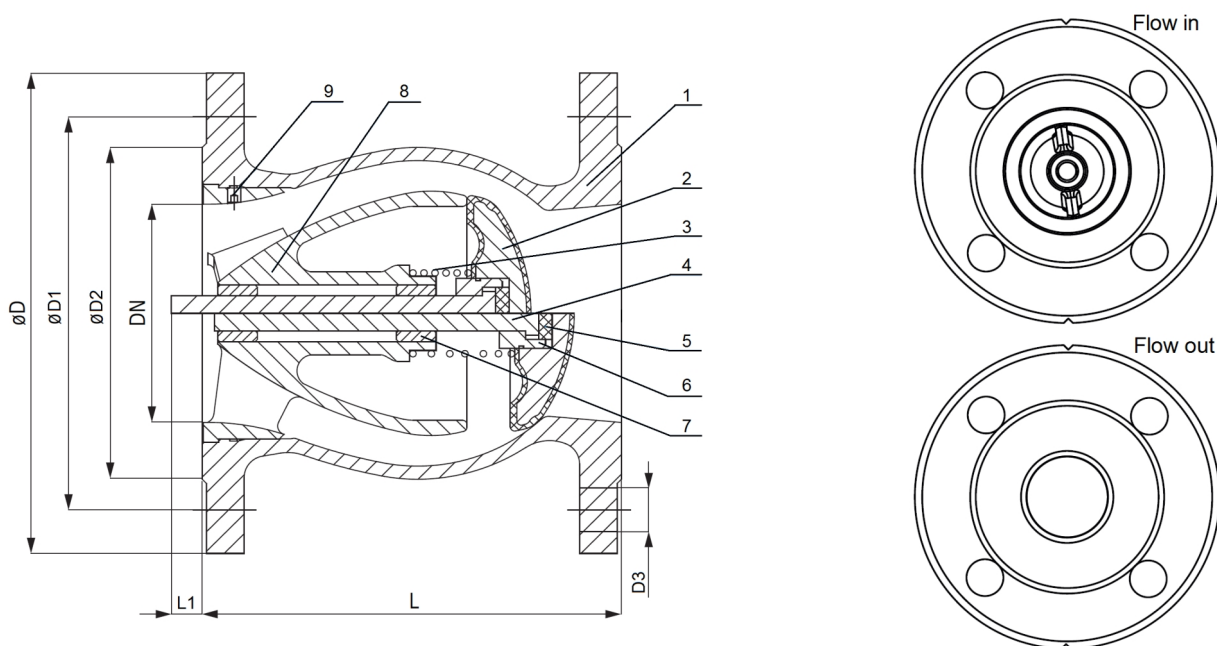
AVK NOZZLE CHECK VALVE, SINGLE STEM, PN10/16**876/00-001****SS 420 stem, SS 304 spring, alu-bronze bushings, A2 fasteners, FBE coating, EPDM rubber****Component list:**

1. Body	Ductile iron GJS-500-7 (GGG-50)	6. Nut	Stainless steel A2
2. Disc	Ductile iron, EPDM encapsulated	7. Bushing	Alu-bronze C61900
3. Spring	Stainless steel 304	8. Diffuser sleeve	Ductile iron GJS-500-7 (GGG-50)
4. Stem	Stainless steel 420	9. Set screw	Stainless steel A2
5. Washer	EPDM rubber		

Components may be substituted with equivalent or higher class materials without prior notification.

Reference nos. and dimensions:

AVK ref. no.	DN	Flange	D	D1	D2	D3	Bolt	L	L1	Theoretical
	mm	drilling	mm	mm	mm	mm	No.	mm	mm	weight/kg
876-0050-00-11102012	50	PN16	165	125	99	19	4	150	8	6.0
876-0065-00-11102012	65	PN16	185	145	118	19	4	170	15	9.0
876-0080-00-11102012	80	PN16	200	160	132	19	8	180	18	11
876-0100-00-11102012	100	PN16	220	180	156	19	8	190	20	15
876-0125-00-11102012	125	PN16	250	210	184	19	8	200	21	19
876-0150-00-11102012	150	PN16	285	240	211	23	8	210	25	26
876-0200-00-01102012	200	PN10	340	295	266	23	8	230	30	39
876-0200-00-11102012	200	PN16	340	295	266	23	12	230	30	39
876-0250-00-01102012	250	PN10	395	350	319	23	12	250	40	57
876-0250-00-11102012	250	PN16	405	355	319	28	12	250	40	57
876-0300-00-01102012	300	PN10	445	400	370	23	12	270	45	73
876-0300-00-11102012	300	PN16	460	410	370	28	12	270	45	73
876-0350-00-01102012	350	PN10	505	460	429	23	16	290	50	109
876-0350-00-11102012	350	PN16	520	470	429	28	16	290	50	109

The designs, materials and specifications shown are subject to change without notice. This is due to the continuous development of our product programme.

