



AVK FLANGED CROSS
CROSS W/FLANGED BRANCH, PN 10/16

712/1610-001



AVK's range of fittings comprises a wide selection of variants with socket and flange connection. The fittings are made of ductile iron GJS-500-7 and are epoxy coated according to DIN 3476 and GSK specifications - internally and externally.



Product description:

Flanged cross type TT with flanged branch to EN 545 for water, waste water and neutral liquids to max. 70° C

Design standards:

- EN 545
- Flange drilling to EN1092, PN10/16

Features:

- Ductile iron fitting to EN 545
- Body of GJS-500-7
- Epoxy coated to DIN 3476 and GSK internally and externally



Expect ... **AVK**

The designs, materials and specifications shown are subject to change without notice due to the continuous development of our product range.

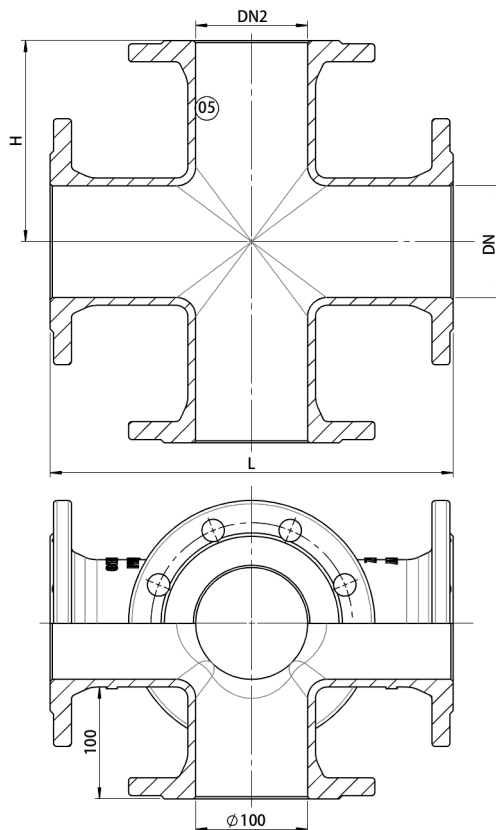

Component list:

1. Fitting	Ductile Iron
------------	--------------

Components may be substituted with equivalent or higher class materials without prior notification.

Reference nos. and dimensions:

AVK ref. no.	DN mm	DN2 mm	Flange drilling	L mm	H mm	Theoretical weight/kg
712-0100-16-101	100	100	PN10/16	360	180	27
712-0125-16-101	125	125	PN10/16	400	200	40
712-0150-16-101	150	150	PN10/16	440	220	41
712-0152-16-101	150	100	PN10/16	440	210	36
712-0200-16-100	200	200	PN10	520	260	59
712-0200-16-101	200	200	PN16	520	260	58
712-0201-16-100	200	150	PN10	520	250	52
712-0201-16-101	200	150	PN16	520	250	52
712-0203-16-100	200	100	PN10	520	240	46
712-0203-16-101	200	100	PN16	520	240	46
712-0250-16-100	250	250	PN10	700	350	93
712-0250-16-101	250	250	PN16	700	350	92
712-0251-16-100	250	200	PN10	700	325	98
712-0251-16-101	250	200	PN16	700	325	98
712-0252-16-100	250	150	PN10	485	280	88
712-0252-16-101	250	150	PN16	485	280	88
712-0254-16-100	250	100	PN10	700	275	80
712-0254-16-101	250	100	PN16	700	275	67
712-0300-16-100	300	300	PN10	800	400	155
712-0300-16-101	300	300	PN16	800	400	155
712-0301-16-100	300	250	PN10	620	330	137
712-0301-16-101	300	250	PN16	620	330	137
712-0302-16-100	300	200	PN10	800	350	124
712-0302-16-101	300	200	PN16	800	350	124
712-0303-16-100	300	150	PN10	505	310	114

The designs, materials and specifications shown are subject to change without notice due to the continuous development of our product range.

AVK FLANGED CROSS
CROSS W/FLANGED BRANCH, PN 10/16

712/1610-001

Reference nos. and dimensions:

AVK ref. no.	DN mm	DN2 mm	Flange drilling	L mm	H mm	Theoretical weight/kg
712-0303-16-101	300	150	PN16	505	310	114
712-0305-16-100	300	100	PN10	800	300	107
712-0305-16-101	300	100	PN16	800	300	107
712-0400-16-100	400	400	PN10	900	450	262
712-0400-16-101	400	400	PN16	900	450	262
712-0500-16-100	500	500	PN10	1000	500	405
712-0500-16-101	500	500	PN16	1000	500	405
712-0600-16-100	600	600	PN10	1100	550	587
712-0600-16-101	600	600	PN16	1100	550	587