



AVK FLANGED TEE

712/1010-001

PN 10/16



AVK's range of fittings comprises a wide selection of variants with socket and flange connection. The fittings are made of ductile iron GJS-500-7 and are epoxy coated according to DIN 3476 and GSK specifications - internally and externally.



Product description:

All flanged Tee type T to EN 545 for water, waste water and neutral liquids to max. 70° C

Design standards:

- EN 545
- Flange drilling to EN1092, PN10/16

Test/Approvals:

- Belgaqua approved material

Features:

- Ductile iron fitting to EN 545
- Body of GJS-500-7
- Epoxy coated to DIN 3476 and GSK internally and externally



BELGAQUA

Expect ... **AVK**

The designs, materials and specifications shown are subject to change without notice due to the continuous development of our product range.

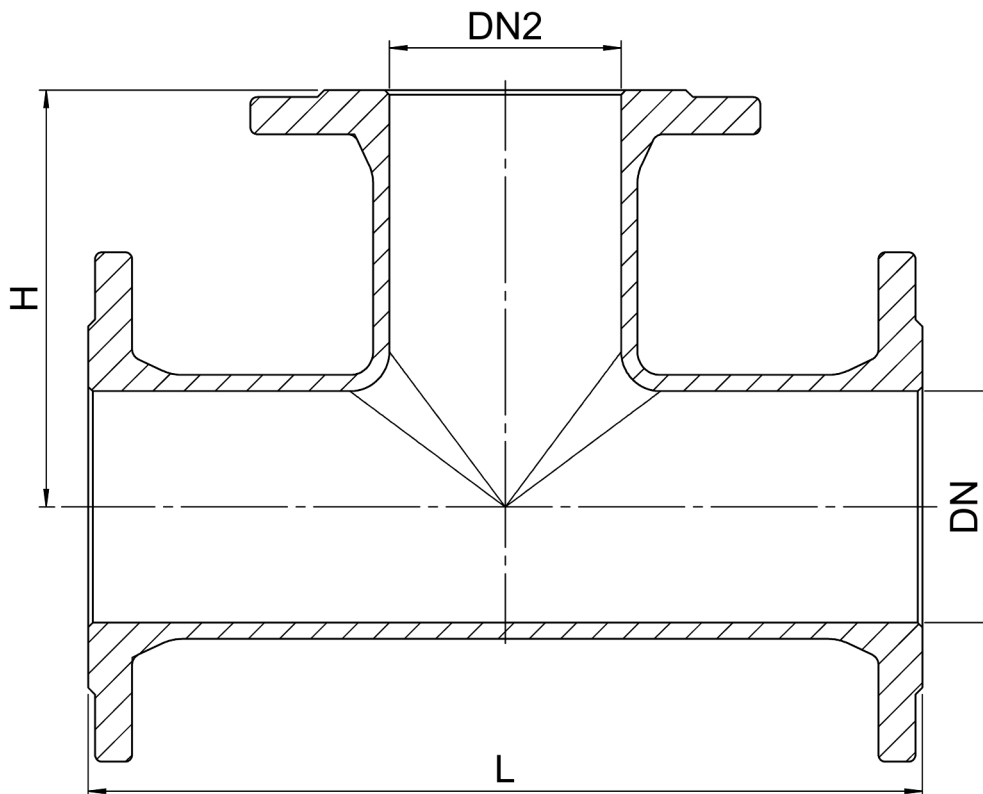

Component list:

1. Fitting	Ductile Iron
------------	--------------

Components may be substituted with equivalent or higher class materials without prior notification.

Reference nos. and dimensions:

AVK ref. no.	DN mm	DN2 mm	Flange drilling	L mm	H mm	Theoretical weight/kg
712-0040-10-101	40	40	PN10/16	280	140	8.0
712-0050-10-101	50	50	PN10/16	300	150	9.9
712-0051-10-101	50	40	PN10/16	300	145	9.7
712-0065-10-101	65	65	PN10/16	330	165	13
712-0066-10-101	65	50	PN10/16	330	158	12
712-0067-10-101	65	40	PN10/16	330	153	12
712-0080-10-101	80	80	PN10/16	330	165	14
712-0081-10-101	80	65	PN10/16	330	160	14
712-0082-10-101	80	50	PN10/16	330	160	13
712-0083-10-101	80	40	PN10/16	310	135	12
712-0100-10-101	100	100	PN10/16	360	180	18
712-0101-10-101	100	80	PN10/16	360	175	17
712-0102-10-101	100	65	PN10/16	360	170	17
712-0103-10-101	100	50	PN10/16	360	170	16
712-0104-10-101	100	40	PN10/16	320	145	14
712-0125-10-101	125	125	PN10/16	400	200	23
712-0126-10-101	125	100	PN10/16	400	195	21
712-0127-10-101	125	80	PN10/16	400	190	21
712-0128-10-101	125	65	PN10/16	400	185	20
712-0129-10-101	125	50	PN10/16	400	185	19
712-0130-10-101	125	40	PN10/16	330	160	17
712-0150-10-101	150	150	PN10/16	440	220	29
712-0151-10-101	150	125	PN10/16	440	215	27
712-0152-10-101	150	100	PN10/16	440	210	26
712-0153-10-101	150	80	PN10/16	440	205	25
712-0154-10-101	150	65	PN10/16	340	180	24
712-0155-10-101	150	50	PN10/16	340	180	24
712-0156-10-101	150	40	PN10/16	340	170	21
712-0200-10-100	200	200	PN10	520	260	43
712-0200-10-101	200	200	PN16	520	260	43
712-0201-10-100	200	150	PN10	520	250	40
712-0201-10-101	200	150	PN16	520	250	39
712-0202-10-100	200	125	PN10	435	240	35
712-0202-10-101	200	125	PN16	435	240	35
712-0203-10-100	200	100	PN10	520	240	37
712-0203-10-101	200	100	PN16	520	240	37
712-0204-10-100	200	80	PN10	520	235	37
712-0204-10-101	200	80	PN16	520	235	36
712-0205-10-100	200	65	PN10	365	215	30
712-0205-10-101	200	65	PN16	365	215	30
712-0206-10-100	200	50	PN10	365	205	29
712-0206-10-101	200	50	PN16	365	205	29
712-0207-10-100	200	40	PN10	365	195	29
712-0207-10-101	200	40	PN16	365	195	28
712-0250-10-100	250	250	PN10	700	350	70
712-0250-10-101	250	250	PN16	700	350	70
712-0251-10-100	250	200	PN10	700	325	64
712-0251-10-101	250	200	PN16	700	325	64
712-0252-10-100	250	150	PN10	700	300	60
712-0252-10-101	250	150	PN16	700	300	60
712-0253-10-100	250	125	PN10	700	275	47
712-0253-10-101	250	125	PN16	700	275	47
712-0254-10-100	250	100	PN10	700	275	57
712-0254-10-101	250	100	PN16	700	275	57
712-0255-10-100	250	80	PN10	700	265	56
712-0255-10-101	250	80	PN16	700	265	56
712-0256-10-100	250	65	PN10	385	260	41
712-0256-10-101	250	65	PN16	385	260	41
712-0257-10-100	250	50	PN10	TBD	TBD	-
712-0257-10-101	250	50	PN16	TBD	TBD	-

The designs, materials and specifications shown are subject to change without notice due to the continuous development of our product range.

Reference nos. and dimensions:

AVK ref. no.	DN mm	DN2 mm	Flange drilling	L mm	H mm	Theoretical weight/kg
712-0258-10-100	250	40	PN10	TBD	TBD	-
712-0258-10-101	250	40	PN16	TBD	TBD	-
712-0300-10-100	300	300	PN10	800	400	99
712-0300-10-101	300	300	PN16	800	400	98
712-0301-10-100	300	250	PN10	620	330	79
712-0301-10-101	300	250	PN16	620	330	78
712-0302-10-100	300	200	PN10	800	350	85
712-0302-10-101	300	200	PN16	800	350	85
712-0303-10-100	300	150	PN10	505	310	64
712-0303-10-101	300	150	PN16	505	310	63
712-0304-10-100	300	125	PN10	TBD	TBD	-
712-0304-10-101	300	125	PN16	TBD	TBD	-
712-0305-10-100	300	100	PN10	800	300	78
712-0305-10-101	300	100	PN16	800	300	78
712-0306-10-100	300	80	PN10	800	290	77
712-0306-10-101	300	80	PN16	800	290	77
712-0307-10-100	300	65	PN10	405	290	54
712-0307-10-101	300	65	PN16	405	290	54
712-0308-10-100	300	50	PN10	TBD	TBD	-
712-0308-10-101	300	50	PN16	TBD	TBD	-
712-0309-10-100	300	40	PN10	TBD	TBD	-
712-0309-10-101	300	40	PN16	TBD	TBD	-
712-0349-10-100	350	300	PN10	850	425	116
712-0349-10-101	350	300	PN16	850	425	123
712-0350-10-100	350	350	PN10	760	380	111
712-0350-10-101	350	350	PN16	760	380	129
712-0352-10-100	350	250	PN10	645	360	93
712-0352-10-101	350	250	PN16	645	360	99
712-0353-10-100	350	200	PN10	850	325	104
712-0353-10-101	350	200	PN16	850	325	110
712-0354-10-100	350	150	PN10	530	340	77
712-0354-10-101	350	150	PN16	530	340	83
712-0356-10-100	350	100	PN10	470	330	70
712-0356-10-101	350	100	PN16	470	330	104
712-0357-10-100	350	80	PN10	445	325	67
712-0357-10-101	350	80	PN16	445	325	73
712-0358-10-100	350	65	PN10	430	320	66
712-0358-10-101	350	65	PN16	430	320	72
712-0359-10-100	350	50	PN10	TBD	TBD	-
712-0359-10-101	350	50	PN16	TBD	TBD	-
712-0360-10-100	350	40	PN10	TBD	TBD	-
712-0360-10-101	350	40	PN16	TBD	TBD	-
712-0400-10-100	400	400	PN10	900	450	156
712-0400-10-101	400	400	PN16	900	450	166
712-0401-10-100	400	350	PN10	900	450	149
712-0401-10-101	400	350	PN16	900	450	159
712-0402-10-100	400	300	PN10	900	350	140
712-0402-10-101	400	300	PN16	900	350	150
712-0403-10-100	400	250	PN10	900	350	130
712-0403-10-101	400	250	PN16	665	390	140
712-0404-10-100	400	200	PN10	900	350	127
712-0404-10-101	400	200	PN16	900	350	137
712-0405-10-100	400	150	PN10	900	350	124
712-0405-10-101	400	150	PN16	900	350	134
712-0406-10-100	400	125	PN10	TBD	TBD	-
712-0406-10-101	400	125	PN16	TBD	TBD	-
712-0407-10-100	400	100	PN10	900	350	122
712-0407-10-101	400	100	PN16	900	350	132
712-0408-10-100	400	80	PN10	900	350	121
712-0408-10-101	400	80	PN16	900	350	131

The designs, materials and specifications shown are subject to change without notice due to the continuous development of our product range.

Reference nos. and dimensions:

AVK ref. no.	DN mm	DN2 mm	Flange drilling	L mm	H mm	Theoretical weight/kg
712-0409-10-100	400	65	PN10	TBD	TBD	-
712-0409-10-101	400	65	PN16	TBD	TBD	-
712-0410-10-100	400	50	PN10	TBD	TBD	-
712-0410-10-101	400	50	PN16	TBD	TBD	-
712-0411-10-100	400	40	PN10	TBD	TBD	-
712-0411-10-101	400	40	PN16	TBD	TBD	-
712-0450-10-100	450	450	PN10	950	475	184
712-0450-10-101	450	450	PN16	950	475	218
712-0451-10-100	450	400	PN10	860	450	165
712-0451-10-101	450	400	PN16	860	450	192
712-0452-10-100	450	350	PN10	TBD	TBD	-
712-0452-10-101	450	350	PN16	TBD	TBD	-
712-0453-10-100	450	300	PN10	745	430	142
712-0453-10-101	450	300	PN16	745	430	164
712-0454-10-100	450	250	PN10	690	420	131
712-0454-10-101	450	250	PN16	690	420	153
712-0455-10-100	450	200	PN10	950	375	154
712-0455-10-101	450	200	PN16	950	375	176
712-0456-10-100	450	150	PN10	570	400	111
712-0456-10-101	450	150	PN16	570	400	133
712-0457-10-100	450	125	PN10	TBD	TBD	-
712-0457-10-101	450	125	PN16	TBD	TBD	-
712-0458-10-100	450	100	PN10	950	375	149
712-0458-10-101	450		PN16	950	375	171
712-0459-10-100	450	80	PN10	950	375	149
712-0459-10-101	450	80	PN16	950	375	171
712-0460-10-100	450	65	PN10	TBD	TBD	-
712-0460-10-101	450	65	PN16	TBD	TBD	-
712-0461-10-100	450	50	PN10	TBD	TBD	-
712-0461-10-101	450	50	PN16	TBD	TBD	-
712-0462-10-100	450	40	PN10	TBD	TBD	-
712-0462-10-101	450	40	PN16	TBD	TBD	-
712-0500-10-100	500	500	PN10	1000	500	216
712-0500-10-101	500	500	PN16	1000	500	260
712-0501-10-100	500	450	PN10	1000	500	209
712-0501-10-101	500	450	PN16	1000	500	248
712-0502-10-100	500	400	PN10	1000	500	204
712-0502-10-101	500	400	PN16	1000	500	236
712-0503-10-100	500	350	PN10	1000	500	198
712-0503-10-101	500	350	PN16	1000	500	231
712-0504-10-100	500	300	PN10	1000	500	194
712-0504-10-101	500	300	PN16	1000	500	223
712-0505-10-100	500	250	PN10	1000	400	184
712-0505-10-101	500	250	PN16	1000	400	214
712-0506-10-100	500	200	PN10	1000	400	181
712-0506-10-101	500	200	PN16	1000	400	210
712-0507-10-100	500	150	PN10	1000	400	178
712-0507-10-101	500	150	PN16	1000	400	208
712-0508-10-100	500	125	PN10	1000	400	177
712-0508-10-101	500	125	PN16	1000	400	207
712-0509-10-100	500	100	PN10	1000	400	176
712-0509-10-101	500	100	PN16	1000	400	206
712-0510-10-100	500	80	PN10	1000	400	176
712-0510-10-101	500	80	PN16	1000	400	205
712-0511-10-100	500	65	PN10	TBD	TBD	-
712-0511-10-101	500	65	PN16	TBD	TBD	-
712-0512-10-100	500	50	PN10	TBD	TBD	-
712-0512-10-101	500	50	PN16	TBD	TBD	-
712-0513-10-100	500	40	PN10	TBD	TBD	-
712-0513-10-101	500	40	PN16	TBD	TBD	-

The designs, materials and specifications shown are subject to change without notice due to the continuous development of our product range.

Reference nos. and dimensions:

AVK ref. no.	DN mm	DN2 mm	Flange drilling	L mm	H mm	Theoretical weight/kg
712-0600-10-100	600	600	PN10	1100	550	303
712-0600-10-101	600	600	PN16	1100	550	380
712-0601-10-100	600	500	PN10	1100	550	286
712-0601-10-101	600	500	PN16	1100	550	352
712-0602-10-100	600	450	PN10	1100	550	281
712-0602-10-101	600	450	PN16	1100	550	342
712-0603-10-100	600	400	PN10	1100	550	275
712-0603-10-101	600	400	PN16	1100	550	332
712-0604-10-100	600	350	PN10	1100	550	271
712-0604-10-101	600	350	PN16	1100	550	325
712-0605-10-100	600	300	PN10	1100	550	267
712-0605-10-101	600	300	PN16	1100	550	318
712-0606-10-100	600	250	PN10	1100	450	257
712-0606-10-101	600	250	PN16	1100	450	308
712-0607-10-100	600	200	PN10	1100	450	254
712-0607-10-101	600	200	PN16	1100	450	305
712-0608-10-100	600	150	PN10	1100	450	251
712-0608-10-101	200	150	PN16	1100	450	303
712-0609-10-100	600	125	PN10	TBD	TBD	-
712-0609-10-101	600	125	PN16	TBD	TBD	-
712-0610-10-100	600	100	PN10	1100	450	250
712-0610-10-101	600	100	PN16	1100	450	301
712-0611-10-100	600	80	PN10	1100	450	249
712-0611-10-101	600	80	PN16	1100	450	300
712-0612-10-100	600	65	PN10	TBD	TBD	-
712-0612-10-101	600	65	PN16	TBD	TBD	-
712-0613-10-100	600	50	PN10	TBD	TBD	-
712-0613-10-101	600	50	PN16	TBD	TBD	-
712-0614-10-100	600	40	PN10	TBD	TBD	-
712-0614-10-101	600	40	PN16	TBD	TBD	-