



AVK FLANGED
BEND 30°, PN 10/16

712/0310-001

AVK's range of fittings comprises a wide selection of variants with socket and flange connection. The fittings are made of ductile iron GJS-500-7 and are epoxy coated according to DIN 30677-2 and GSK specifications - internally and externally.

Product description:

Double flanged bend 30° type FFK to EN 545 for water, waste water and neutral liquids to max. 70° C

Design standards:

- EN 545
- Flange drilling to EN1092, PN10/16

Features:

- Ductile iron fitting to EN 545
- Body of GJS-500-7
- Epoxy coated to DIN 3476 and GSK internally and externally



Expect... **AVK**

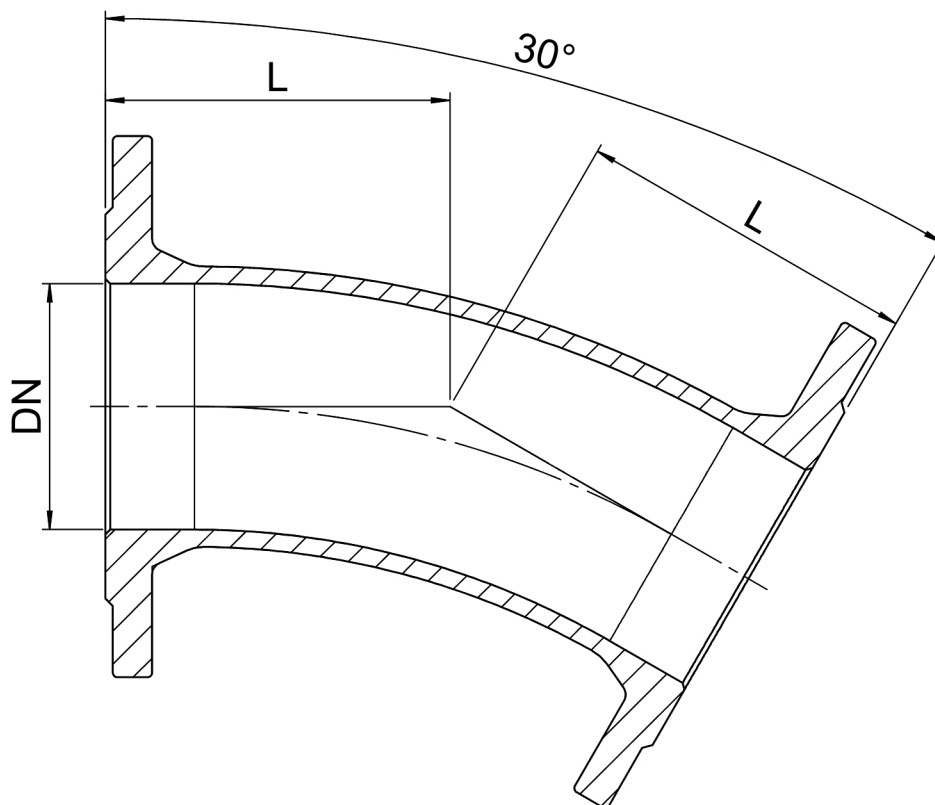

Component list:

1. Fitting	Ductile Iron
------------	--------------

Components may be substituted with equivalent or higher class materials without prior notification.

Reference nos. and dimensions:

AVK ref. no.	DN mm	Flange drilling	L mm	Theoretical weight/kg
712-0040-03-101	40	PN10/16	140	7.0
712-0050-03-101	50	PN10/16	150	8.0
712-0065-03-101	65	PN16	165	8.5
712-0080-03-101	80	PN10/16	130	9.1
712-0100-03-101	100	PN10/16	140	11
712-0125-03-101	125	PN10/16	150	15
712-0150-03-101	150	PN10/16	160	18
712-0200-03-100	200	PN10	180	26
712-0200-03-101	200	PN16	180	26
712-0250-03-100	250	PN10	210	39
712-0250-03-101	250	PN16	210	38
712-0300-03-100	300	PN10	255	56
712-0300-03-101	300	PN16	255	55
712-0350-03-100	350	PN10	217	79
712-0350-03-101	350	PN16	217	85
712-0400-03-100	400	PN10	324	90
712-0400-03-101	400	PN16	324	100
712-0450-03-100	450	PN10	349	107
712-0450-03-101	450	PN16	349	122
712-0500-03-100	500	PN10	273	118
712-0500-03-101	500	PN16	273	147
712-0600-03-100	600	PN10	279	203
712-0600-03-101	600	PN16	279	255