



AVK HANDWHEEL FOR FIRE PROTECTION VALVES

08/A-011

Fitting all standard gate valves, #14-27

For manual operation of AVK gate valves. AVK recommends usage of our handwheels. AVK handwheels are of grey cast iron GJL-250 (GG-25) with fusion bonded epoxy coating in compliance with DIN 3476 part 1 and EN 14901.

Product description:

Handwheel assembled with bolt and washer

Features:

Handwheel for gate valves with red epoxy



Expect ... **AVK**

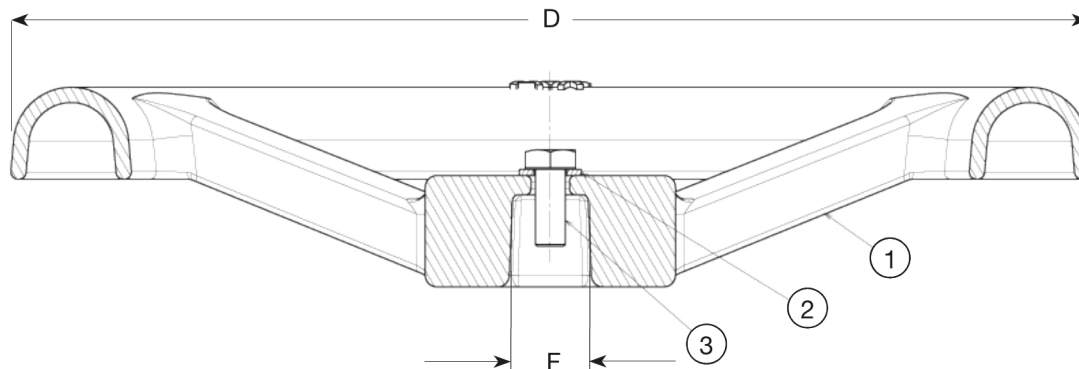

Component list:

1. Handwheel	Cast iron GJL-250 (GG-25)	3. Bolt	Stainless steel A2
2. Washer	Stainless steel A2		

Components may be substituted with equivalent or higher class materials without prior notification.

Reference nos. and dimensions:

AVK ref. no.	DN/DN	D mm	F mm	Theoretical weight/kg
08-050-01-200	40 - 50	180	14	1.5
08-080-02-200	65 - 80	225	17	2.0
08-100-01-200	100 - 100	280	19	3.5
08-150-02-200	125 - 150	320	19	4.5
08-200-01-200	200 - 200	320	24	6.0
08-250-02-200	250 - 300	500	27	11