



## AVK HANDWHEEL, CTC

08/A-010

For gas. Fitting all standard gate valves, DN40-500

For manual operation of AVK gate valves AVK recommends usage of our handwheels. AVK handwheels are of grey cast iron GJL-250 (GG-25) with fusion bonded epoxy coating in compliance with DIN 3476 part 1 and EN 14901.

### Product description:

Handwheel assembled with bolt and washer

### Features:

- Handwheel for gate valves with yellow epoxy, RAL1023



Expect... **AVK**

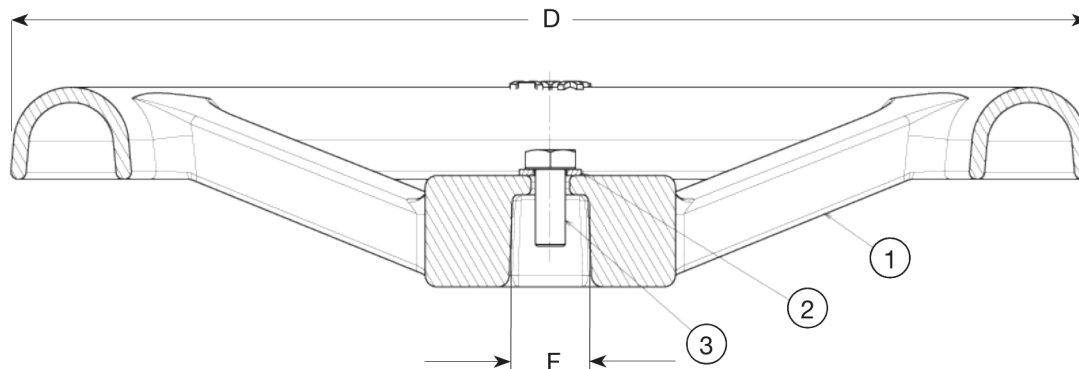

**Component list:**

1. Handwheel	Cast iron GJL-250 (GG-25)	3. Bolt	Stainless steel A2
2. Washer	Stainless steel A2		

Components may be substituted with equivalent or higher class materials without prior notification.

**Reference nos. and dimensions:**

AVK ref. no.	DN/DN	D mm	F mm	Theoretical weight/kg
08-050-01-370	40 - 50	180	14	1.5
08-080-02-370	65 - 80	225	17	2.0
08-100-01-370	100 - 100	280	19	3.5
08-150-02-370	125 - 150	320	19	4.5
08-200-01-370	200 - 200	360	24	6.0
08-250-02-370	250 - 300	500	27	11
08-400-01-370	350 - 500	640	32	17